

NITROX

Nitrogen generator



UHP Laboratory Nitrogen Gas Generators Installation, Commissioning, Operation & Maintenance Guide



Read Before
Operating



UHPLCMS, UHPICP & UHPN5001/0 Models

Section		Page
1	INSTALLATION	
1.1	Safety Warning	1
1.2	General Information	1
1.3	Location of the Generator	2
1.4	Installation Procedure	2
1.5	Recommended System Layouts	3
1.5.1	● Basic Layout	3
1.5.2	● Installation with Back-up Supply	3
2	COMMISSIONING	
2.1	External Instruments and Connections	4
2.2	Internal Instruments	5
2.3	Commissioning Procedure	6
3	MAINTENANCE	
3.1	Service Indicators	7
3.1.1	● Normal Usage Mode	7
3.1.2	● Service Required	7
3.1.3	● Service Overdue	7
3.1.4	● Service Meter Reset	7
3.2	Service Kits	8
3.2.1	Service Kit Contents	8
3.3	Spare Parts	8

1.1 - Safety Warning

Do not operate the generator until the information contained in this document has been read and understood by all personnel concerned. Nitrogen is not a poisonous gas but, in a concentrated form, there is a risk of asphyxiation. The generator produces a small flow of nitrogen which quickly disperses in the atmosphere. However, do not directly inhale the output gas from the outlet pipe. Personnel handling, using or maintaining this generator must employ safe working practices and observe all relevant local health and safety regulations.

1.2 - General Information

domnick hunter nitrogen gas generators will produce a constant stream of nitrogen at a pre-selected flow and purity when connected to a suitable power supply (plus a compressed air supply for non-compressor models). They are suitable for use in laboratories and light industrial environments. The generators are classified as non-hazardous for transportation purposes and as non-flammable for fire regulations. (Any fire should be fought by means appropriate to the material causing the fire with the exception being the use of water.) The door is manufactured from polyurethane, is CFC-free and conforms to UL 94 VO fire retardant specifications. Disposal of the unit should be at a licensed landfill site.

NOTE:

Any interference with the calibration warning labels will invalidate the generator's warranty and may incur costs for the re-calibration of the generator.

1.3 - Location of the Generator

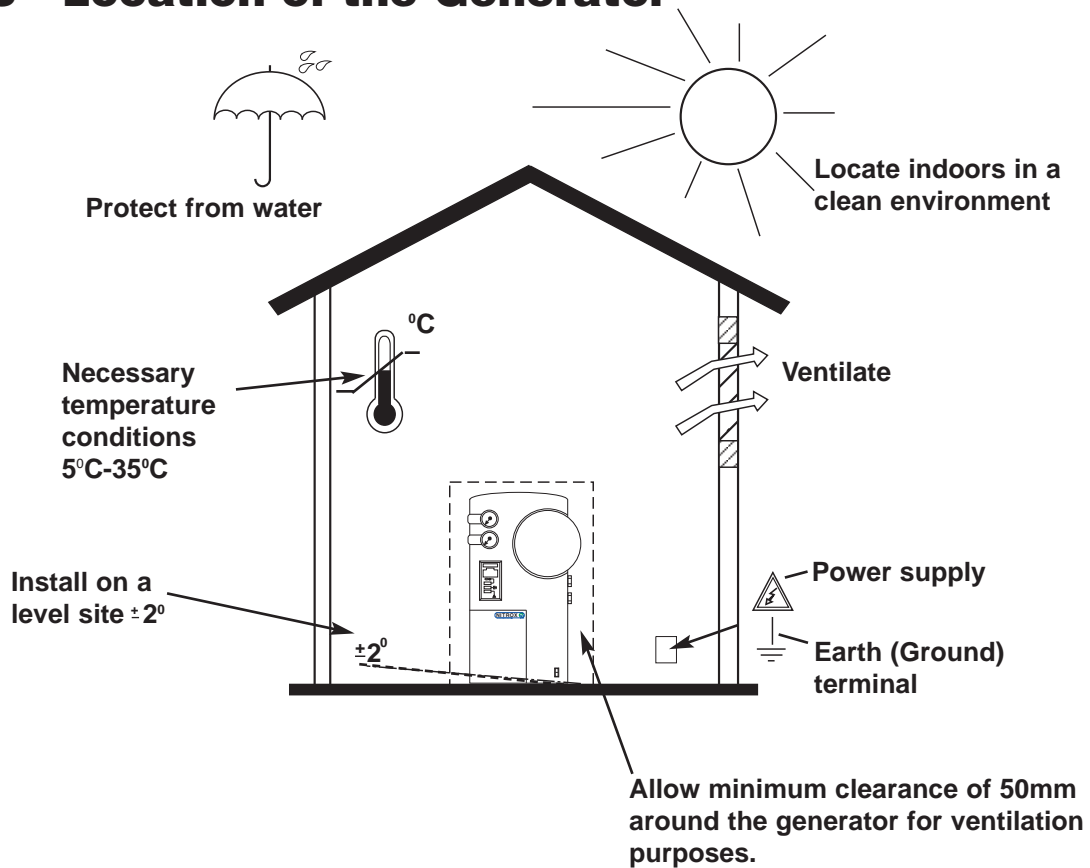

1.4 - Installation Procedure

- 1) Locate generator in the position it will normally be sited. We recommend that the generator be sited as close to the application as possible but do not connect gas supply pipework to generator. **Refer to page 3 for System Layouts and pipework recommendations.**
- 2) Remove blanking plug from the outlet port on the side of the generator and store in the door pocket.
- 3) Connect the drain port hose assembly to the drain port on the rear of the generator and position the MIST-X silencer in the desired location. Note : The MIST-X silencer should be mounted vertically to allow efficient draining. i.e. with the white cap at the bottom.
- 4) Connect the mains lead to the electrical connector on the rear of the generator and connect to a suitably rated power supply (230V or 110V) ensuring that an earth connection exists.



1 - INSTALLATION

1.5 - Recommended System Layouts

1.5.1 - Basic Layout

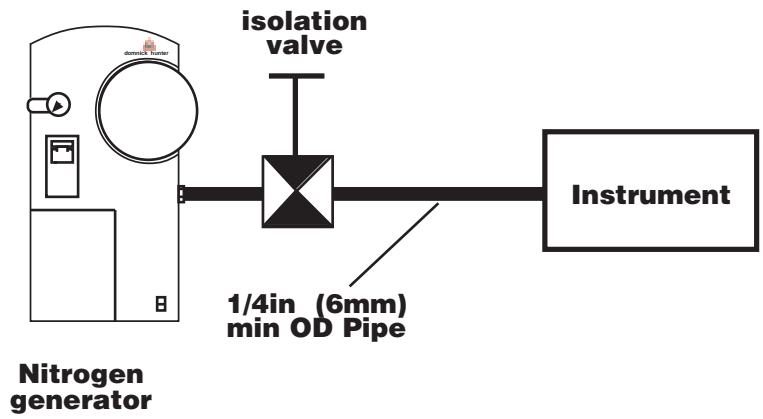

1.5.2 - Installation with Back-up Supply

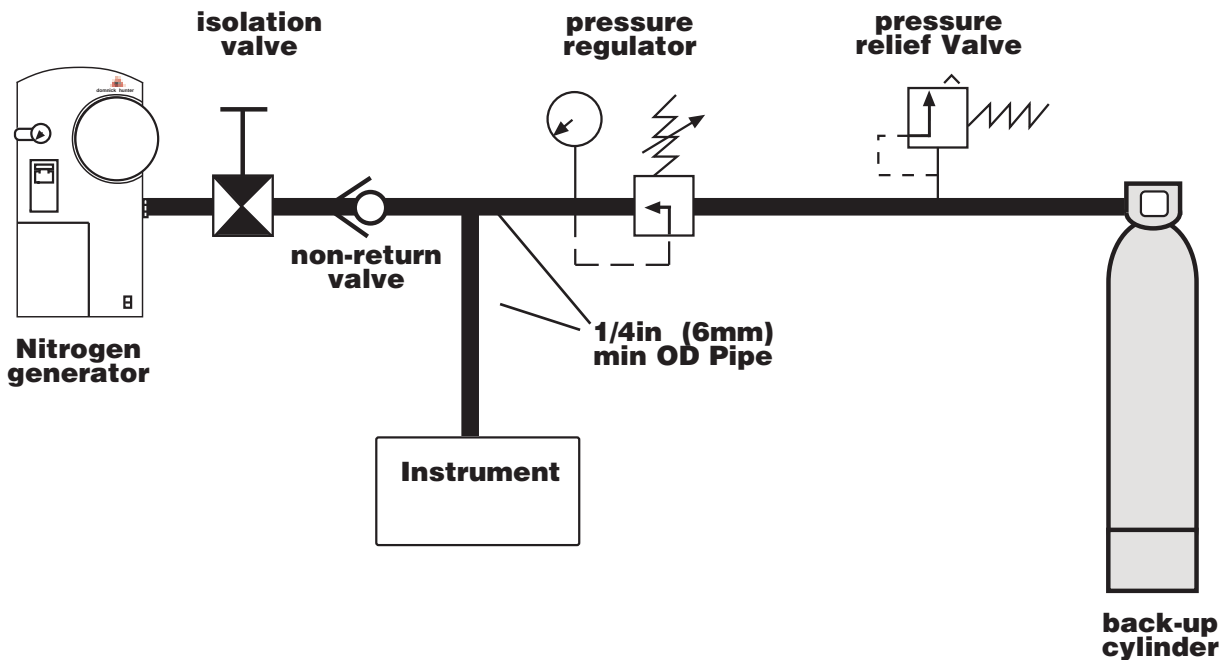

2.1 - External Instruments and Connections

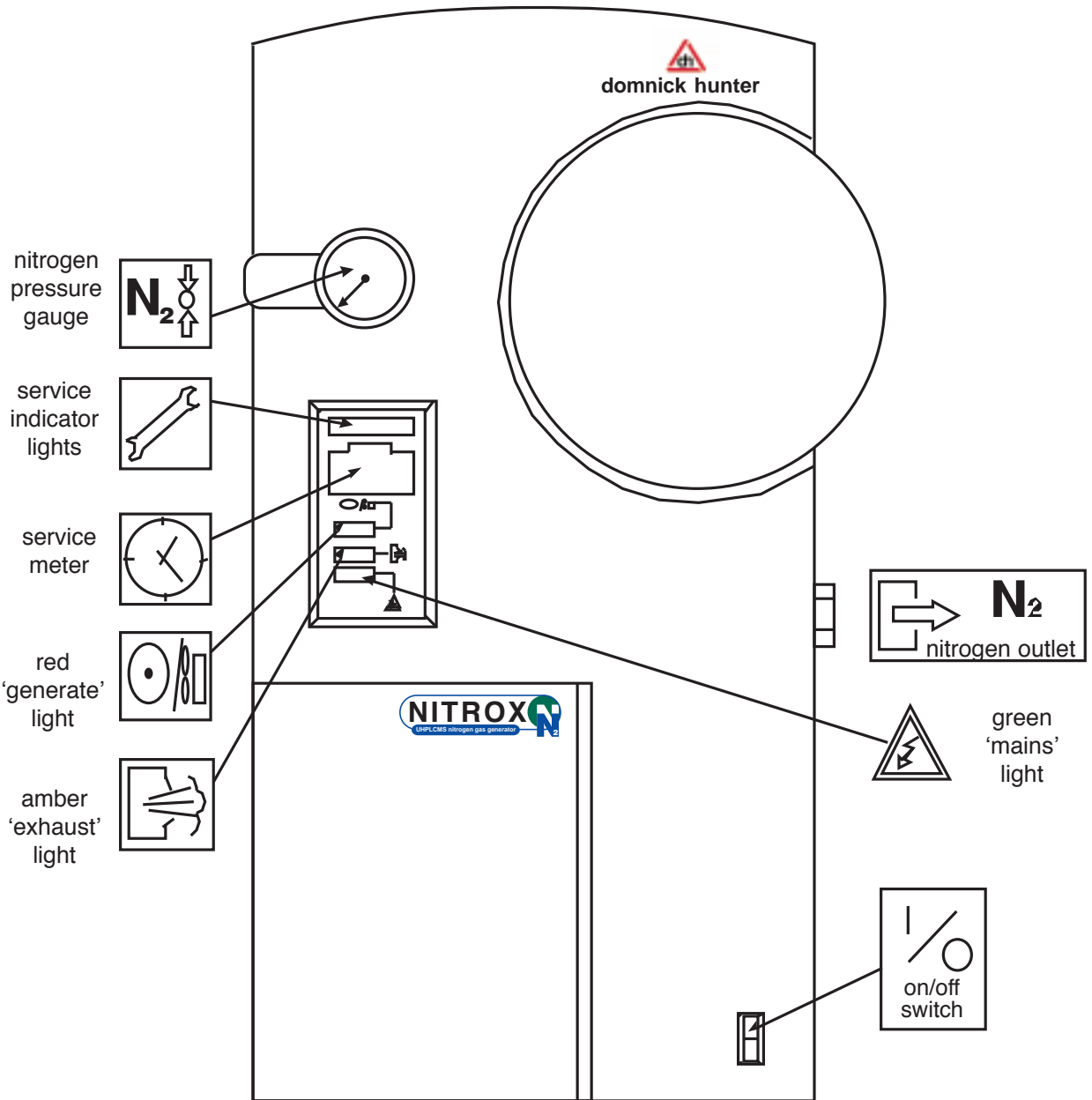

2 - COMMISSIONING

2.2 - Internal Instruments

Start up procedure (after maintenance)

1. Connect the generator to a mains supply
2. Close the generator front door
3. Switch on using the On/Off switch on the front of the unit and note the green mains light illuminate
4. Run the generator for one hour before connecting to any applications

Nitrogen Outlet Pressure



Service Meter

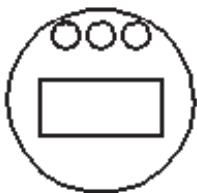

Service Meter Reset



Generate Light
Exhaust Light
Mains Light

Nitrogen Pressure Regulator



Nitrogen Reservoir Pressure



Air Inlet Pressure

2.3 - Commissioning Procedure

- 1) Ensure that the door is closed.
- 2) Switch on using the on/off switch located on the front of the generator. Note green "mains" light illuminate (if light does not illuminate, refer to the fault finding diagnostic chart on page 17).
- 3) The amber "exhaust" light will illuminate for between 60-120 seconds then the red "generate" light will illuminate for between 60-120 seconds.
- 4) The generator will then cycle automatically between the amber "exhaust" and red "generate" lights indicating that the generator is operating correctly.

The generator should be run for the time shown below, prior to the first time of operation to ensure the required purity is achieved.

- 5) After initial running, connect the generator to the application pipework via the outlet port. (Note: The application supply pipework will need to be flushed for one hour by the generator for every 10m of pipework before normal operation can proceed.)
- 6) The generator is now supplying gas to the application.

Note: The generator is designed to run continuously; in the event of any kind of interruption to the operation, repeat the start-up procedure on page 5 to ensure the purity of the nitrogen to your application.

Model	Time to reach purity
UHPLCMS12/18	2 hours
UHPICP5001/0	4 hours
UHPN5001/0	4 hours

3.1 - Service Indicators

To maintain the quality of gas to your application, observe the maintenance requirement outlined below. **Keep a written record of all maintenance undertaken.** Order any replacement parts before you require the maintenance to take place. Use only genuine **domnick hunter** parts as supplied by **domnick hunter** or your appointed agent. Failure to do so may result in reduced performance of your generator and hence your ability to process your work. The maintenance described is designed to be undertaken by the user. If, however, you require the assistance of **domnick hunter** or its appointed agents, contact them quoting the model number of the unit taken from the front of the door.

The service meter is totally automated and indicates when the generator requires routine maintenance by indicating the amount of time elapsed since the last maintenance was undertaken. The operating sequence is illustrated below.

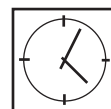
**3.1.1 - Normal Usage Mode**

When the green light is illuminated, this indicates the generator is operating normally and that no maintenance needs to be undertaken at this time.

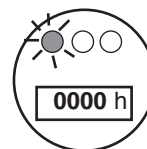
**3.1.2 - Service Required**

When the amber light is illuminated, routine maintenance should be scheduled. Order the appropriate service kit from your sales outlet. The light illuminates after 3,600 hours' operation and maintenance is due every 4,000 hours.

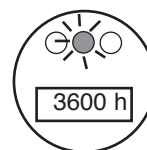
**3.1.3 - Service Overdue**

When the red light illuminates, your generator is overdue for maintenance. We recommend that you contact your sales outlet to order the appropriate service kit immediately. The light illuminates after 4,000 hours of operation.

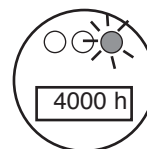
**3.1.4 - Service Meter Reset**

After completing the maintenance and updating the service schedule, the service meter reset button* should be pressed for five seconds to reset the meter back to zero in order to indicate when maintenance is required in the future.

* The reset button is located on the fascia behind the door (see Internal Instruments on page 5).

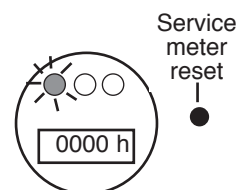

3.2 - Service Kits

Description	Order Code
1) 4,000 Hour Service Kit all models	60 626 0780
2) 24,000 Hour Service Kit - UHPLCMS12, UHPICP5001, UHPN5001 (110V)	60 626 0782
24,000 Hour Service Kit - UHPLCMS12, UHPICP5001, UHPICP5000 (230V)	60 626 0784
3) 24,000 Hour Service Kit - UHPLCMS18, UHPICP5000, UHPN5000 (110V)	60 626 0786
24,000 Hour Service Kit - UHPLCMS18, UHPICP5000, UHPN5000 (240V)	60 626 0788

3.2.1 - Service Kit Contents

4,000 Hour Service Kit

3-off MIST-X silencers for exhaust valves and drain
1-off inlet air filter element

24,000 Hour Service Kit (UHPLCMS12, UHPICP5001 and UHPN5001)

1-off 4,000 Hour Service Kit
1-off Air compressor
1-off Inlet/exhaust solenoid valve assembly

24,000 Hour Service Kit (UHPLCMS18, UHPICP5000 and UHPN5000)

1-off 4,000 Hour Service Kit
1-off Inlet/exhaust solenoid valve assembly
1-off Air inlet valve sub assembly

3.3 Spare Parts

Description	Order Code
4) 1/4" BSP Drain Valve (110V)	60 626 0640
1/4" BSP Drain Valve (230V)	60 626 0642
5) Cooling Fan (110V)	60 626 0644
Cooling Fan (230V)	60 626 0646
6) Service Meter (110V)	60 626 0648
Service Meter (230V)	60 626 0650
7) LED Kit (110V)	60 626 0652
LED Kit (230V)	60 626 0654
8) Air Inlet / N ₂ Outlet Pressure Gauge	60 626 0656
9) N ₂ Reservoir Pressure Gauge	60 626 0658
10) Pressure Regulator	60 626 0796
11) Pressure Relief Valve	60 626 0798
12) Mass Flow Controller	60 626 0664
13) Non-return Valve	60 626 0666
14) PTFE Compressor Hose	60 626 0668
15) PLC	60 626 0670

Caution

Before carrying out any servicing, switch off the generator in accordance with the following shutdown procedure. Failure to comply with these procedures and the installation of non-approved parts could damage the generator and invalidate the warranty.

It is recommended that the service be scheduled for a time when gas is not required and that safety glasses are worn at all times when servicing the generator.

4.1 - Shutdown Procedure

- 1) Close external shut-off valve(s) as indicated in Recommended System Layouts on page 3.
- 2) Turn the generator off using the on/off switch on the front of the generator and leave for five minutes to allow the unit to depressurise.
- 3) **Disconnect the generator from the mains supply.**
- 4) **Models UHPLCMS18, UHPICP5000 and UHPN5000:** Isolate inlet compressed air supply and disconnect from the generator.
- 5) The generator is now shut down.
- 6) **Models UHPLCMS12, UHPICP5001 and UHPN5001:** After shutdown, leave the generator for one hour to allow the compressor to cool down before undertaking maintenance.

4.2 - 4,000 Hour Service Instructions

Read the following procedures fully before starting any maintenance.

Caution

Before carrying out any servicing, switch off the generator in accordance with the Shutdown Procedure on page 9. Failure to comply with these procedures and the installation of non-approved parts could damage the generator and invalidate the warranty.

It is recommended that the service be scheduled for a time when gas is not required and that safety glasses are worn at all times when servicing the generator.

4.3 Maintenance Procedure

Compressor Inlet Filter & Exhaust Silencers

- 1) Ensure mains supply is disconnected.
- 2) Take off left hand side panel.
- 3) Locate the 2-off MIST-X silencers connected to the solenoid valves.
- 4) Remove the 2-off MIST-X silencers from the solenoid valves, turning anti clockwise (do not remove elbows).
- 5) Fit the replacement silencers, turning clockwise until hand tight.
- 6) Before re-connecting to mains, ensure right hand side panel is re-fitted.



4.4 - Maintenance Procedure - Coalescing Filter

- 1) Using a 13mm spanner, loosen the nut on the fitting at the base of the filter housing and release the pipe (fig 1c).
Note: A small amount of air may escape at this point.
Wait until the Air Inlet Pressure Gauge reads zero.
- 2) Twist the body of the filter housing in an anti-clockwise direction until released (fig 2c).
- 3) Unscrew the filter element in an anti-clockwise direction and dispose of the element (fig 3c).
- 4) Fit the replacement element by screwing it in a clockwise direction until hand tight (fig 4c).
- 5) Replace the filter housing body by screwing it in a clockwise direction until hand tight (fig 5c).
- 6) Reconnect the pipe to the elbow at the base of the filter housing and tighten the nut with a 13mm spanner until hand tight (fig 6c).
- 7) Before re-connecting to mains, ensure side panels are re-fitted.

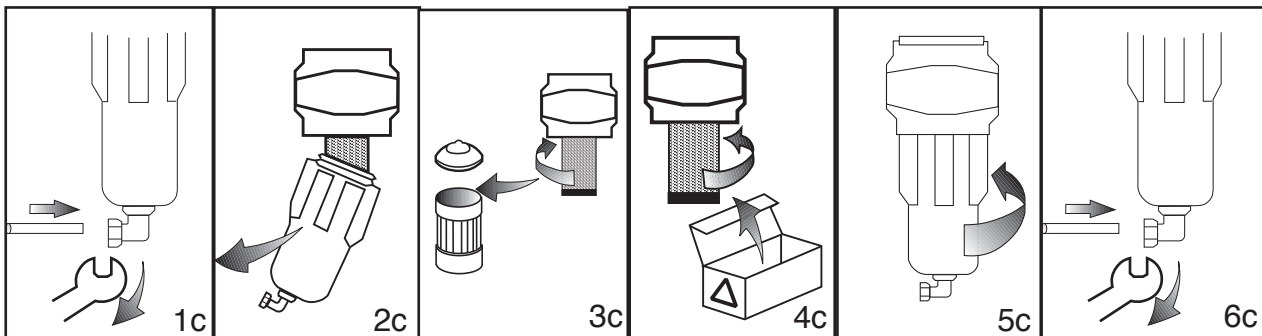
**4.5 - Restart Procedure**

- 1) Re-connect the generator to a suitable mains supply.
- 2) **Models UHPLCMS18, UHPICP5000 and UHPN5000** reconnect compressed air supply.
- 3) Switch on using the on/off switch on the front of the generator.
- 4) Open door, press the service meter reset button, then close the door.
- 5) Open the shut-off valves as indicated in the Recommended System Layouts (page 3).
- 6) Run the generator for one hour minimum before connecting to any applications.

4.6 - 24,000 Hour Service Instructions

Read the following procedures fully before starting any maintenance.

Caution

Before carrying out any servicing, switch off the generator in accordance with the Shutdown Procedure on page 9. Failure to comply with these procedures and the installation of non-approved parts could damage the generator and invalidate the warranty.

It is recommended that the service be scheduled for a time when gas is not required and that safety glasses are worn at all times when servicing the generator.

4.7 - Maintenance Procedure - Solenoid Valves

Tools Required: 1) Phillips & posi screwdrivers 2) Terminal screwdriver
 3) 13mm spanner 4) Medium adjustable spanner

4.7.1 - Replacing the Existing Solenoid Valves



1) Using a Posi-drive screwdriver, remove both side panels.



2) Locate the bracket and solenoid valve assembly on the centre panel.



3) Remove the electrical plug from the valve using a terminal screwdriver, noting their positions.



4) Disconnect the adjoining pipework, noting their positions.



5) Unscrew the MIST-X silencers from each solenoid valve



6) Using a Phillips screwdriver, remove the four screws holding the solenoid valve assembly to the centre panel.



7) Remove the solenoid valve and bracket assy (retain screws to mount new assy). Fitting the replacement assy is the reverse of removal. Ensure the solenoid valve leads are returned to their original positions.

4.8 - Maintenance Procedure - Compressor models only

This procedure should only be undertaken a minimum of one hour after the generator has been shut down in order that it is cool enough to safely handle.

Tools required: 1) 13mm spanner 2) Terminal screwdriver 3) Adjustable spanner
4) Posi screwdriver

4.8.1 - Removing the Existing Compressor

- 1) Using a Posi-drive screwdriver, remove both side panels.

Note: Allow 2.5m space for the side panels to be laid flat.



- 2) Using a 13mm spanner carefully remove the PTFE tube from the generator bulkhead which connects to the compressor.



- 3) Remove the two screws and cover from the electrical connector block located next to the compressor.



- 4) Disconnect the compressor's brown, blue and yellow/green wires from the connector block.



- 5) Locate and remove the four screws on the base of the generator cabinet which hold down the compressor mounting plate. Retain these screws for fixing the replacement compressor.



- 6) Disconnect inlet tube from inlet filter push-in fitting.



- 7) Lift the compressor and mounting plate out of the cabinet and remove the PTFE tube, inlet filter and fittings from the compressor. Make a note of their positions for fitting to the replacement compressor.

- 8) Dispose of the compressor.

Tools required: 1) 13mm spanner 2) Terminal screwdriver
 3) Adjustable spanner 4) Posi screwdriver

4.8.2 - Fitting the Replacement Compressor



1) Unpack the replacement compressor and fit the PTFE tube, air inlet tube and fittings into the head of the compressor using a suitable thread sealant.



2) Fix the mounting plate and compressor into the base of the cabinet using the four screws retained from the original compressor.



3) Re-connect the wires into the connector block matching the coloured wires on each side of the terminal. Ensure ferrule is fully inserted.



4) Re-connect the PTFE tube to the bulkhead and tighten carefully.



5) Reconnect inlet tube from inlet filter push-in fitting.

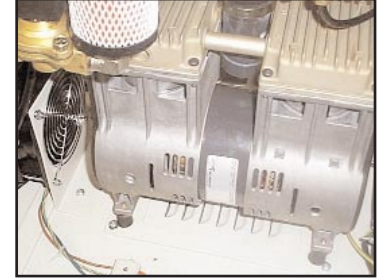

6) The compressor is now installed.

7) Refit the side panels using the screws previously removed.

Note: Take care not to trap any wires leading from the fans.

Note: After any maintenance, check all pipework connections for leaks with a soap solution.

4.9 - Restart Procedure

- 1) Connect the generator to a suitable mains supply.
- 2) **Models UHPLCMS18, UHPICP5000 and UHPN5000:** Reconnect compressed air supply.
- 3) Switch on using the on/off switch on the front of the generator.
- 4) Open door, press the service meter reset button, then close the door.
- 5) Open the shut-off valves as indicated in the Recommended System Layouts (page 3).
- 6) Run the generator for one hour minimum before connecting to any applications.

4.10 - Service Record

Date of Commissioning: / /

Hours	Hours Shown	Date	Serviced by		Comments/Observations
			Print	Initial	
4,000					
8,000					
12,000					
16,000					
20,000					
24,000					
28,000					
32,000					
36,000					
40,000					
44,000					
48,000					

5 - FAULT FINDING GUIDE

Fault	Probable Cause	Remedy
Power connected but NO mains light	Fuse blown	Replace fuse
Power connected to generator, but NO operation	Failure of PLC	Contact sales outlet
Low gas output pressure	Service overdue Internal gas leak External gas leak Compressor fault	Service generator Locate leak and rectify Locate leak and rectify Contact sales outlet

For any problems other than those specified above, contact your sales outlet

6 - INSTALLATION ERRORS

General

- Failure to observe recommended actions outlined in this manual may cause the warranty to be invalidated
- Insufficient ventilation around the generator may cause heat build-up
- Use of non-genuine or non-recommended **domnick hunter** spare parts
- The application requires more gas than can be supplied by the generator which means the wrong generator has been requested or the generator is being used for too many applications at the same time
- Leaks on external nitrogen supply pipework may cause decreased performance and supply of gas to the application

Outlet Connection

- Use of porous or ferrous pipework allowing ingress of oxygen
- Outlet pipe diameter too small causing insufficient gas flow to the application

Electrical

- Voltage drop on incoming supply causing the generator to malfunction
- Incorrect supply cable causing overheating and potential fire risk
- Lack of suitable earth connection causing potential electric shock hazard
- Incorrect mains voltage supply causing the generator to malfunction

7 - TECHNICAL SPECIFICATIONS

P18

Nitrogen Generator Model	UHPLCMS12	UHPLCMS18
Nitrogen Output Flow	12 NL/min	18 NL/min
Nitrogen Output Pressure	7.5barg (110psig)	7.5barg (110psig)
Nitrogen Purity	99.5% (0.5% O₂)	99.5% (0.5% O₂)
Integral Compressor Fitted	Yes	No
Nitrogen Outlet Connection	1/4" Swagelok®	1/4" Swagelok®
Air Inlet Pressure Required	N/A	9.5barg (140psig)
Air Inlet Flow Required	N/A	63 NL/min
Air Inlet Quality Required	N/A	ISO 8573.1 Class 1.2.1 Dirt, Water, Oil
Air Inlet Connection	N/A	G1/8
Power Consumption (VA Nom)	550VA (nom)	50VA (nom)
Fuse Rating	10A (230V models) 10A (110v models)	5A
Electrical Supply Required	230V/50-60Hz/1ph 110V/50-60Hz/1ph	230V/50-60Hz/1ph 110V/50-60Hz/1ph
Dimensions		
Height	835mm (33in)	835mm (33in)
Width	355mm (14in)	355mm (14in)
Depth	670mm (27in)	670mm (19in)
Weight	86Kg (190lb)	75Kg (165lb)

7 - TECHNICAL SPECIFICATIONS

Nitrogen Generator Model	UHPICP5001	UHPICP5000
Nitrogen Output Flow	5 NL/min	5 NL/min
Nitrogen Output Pressure	7.5barg (73psig)	7.5barg (73psig)
Nitrogen Purity	99.99% (100ppm O₂)	99.5% (100ppm O₂)
Integral Compressor Fitted	Yes	No
Nitrogen Outlet Connection	1/4" Swagelok®	1/4" Swagelok®
Air Inlet Pressure Required	N/A	7.0barg (100psig)
Air Inlet Flow Required	N/A	40 NL/min
Air Inlet Quality Required	N/A	ISO 8573.1 Class 1.2.1 Dirt, Water, Oil
Air Inlet Connection	N/A	G¹/₈
Power Consumption (VA Nom)	550VA (nom)	50VA (nom)
Fuse Rating	10A (230V models) 10A (110v models)	5A
Electrical Supply Required	230V/50-60Hz/1ph 110V/50-60Hz/1ph	230V/50-60Hz/1ph 110V/50-60Hz/1ph
Dimensions		
Height	835mm (33in)	835mm (33in)
Width	355mm (14in)	355mm (14in)
Depth	670mm (27in)	670mm (19in)
Weight	86Kg (190lb)	75Kg (165lb)

7 - TECHNICAL SPECIFICATIONS

P20

Nitrogen Generator Model	UHPN5001	UHPN5000			
Nitrogen Output Flow	See table below	See table below			
Nitrogen Output Pressure	5.0barg (73psig)	5.0barg (73psig)			
Integral Compressor Fitted	Yes	No			
Nitrogen Outlet Connection	1/4" Swagelok®	1/4" Swagelok®			
Air Inlet Pressure Required	N/A	7.0barg (100psig)			
Air Inlet Quality Required	N/A	ISO 8573.1 Class 1.2.1 Dirt, Water, Oil			
Air Inlet Connection	N/A	G¹/₈			
Power Consumption (VA Nom)	550VA (nom)	50VA (nom)			
Fuse Rating	10A (230V models) 10A (110v models)	5A			
Electrical Supply Required	230V/50-60Hz/1ph 110V/50-60Hz/1ph	230V/50-60Hz/1ph 110V/50-60Hz/1ph			
Dimensions					
Height	835mm (33in)	835mm (33in)			
Width	355mm (14in)	355mm (14in)			
Depth	670mm (27in)	670mm (19in)			
Weight	86Kg (190lb)	75Kg (165lb)			
Nitrogen Purity vs Flow					
Nitrogen purity (oxygen content)	100ppm	0.1%	0.5%	1%	2%
Nitrogen outlet flow (NL/min)	2.5	4.0	5.0	7.0	8.0
Air inlet flow required (UHPN5000)	20.0	19.0	17.5	22.0	22.0

Wiring Schematic

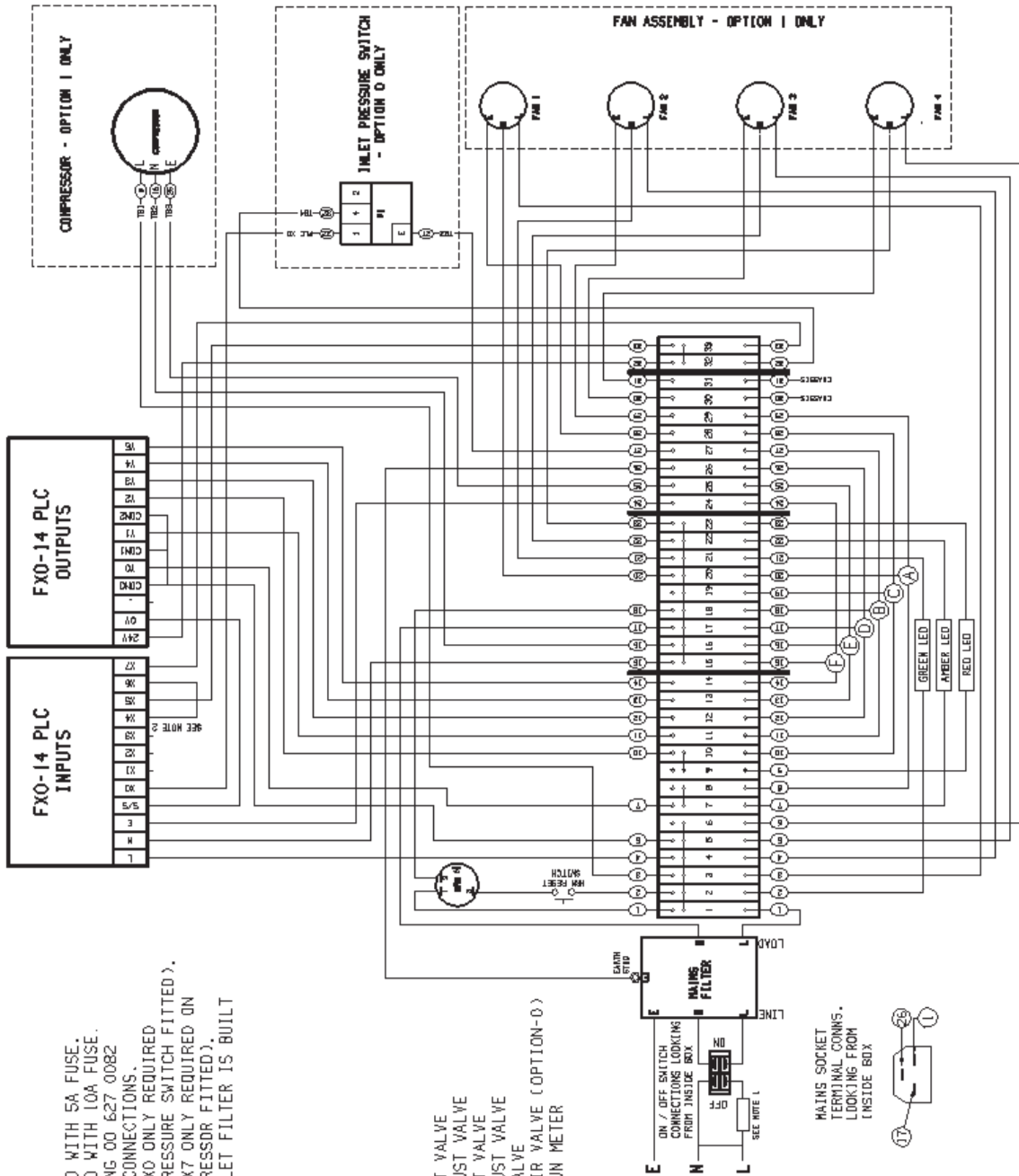

NOTES

1. OPTION-0 FITTED WITH 5A FUSE.
2. OPTION-1 FITTED WITH 10A FUSE.
3. REFER TO DRAWING 00 627 0082 FOR PLC CYCLE CONNECTIONS.
4. CONNECTION TO X0 ONLY REQUIRED ON OPTION-0 (PRESSURE SWITCH FITTED).
5. CONNECTION TO X7 ONLY REQUIRED ON OPTION-1 (COMPRESSOR FITTED).
6. ON OPTION-0 INLET FILTER IS BUILT INTO SWITCH.

KEY

- A LH INLET VALVE
- B RH INLET VALVE
- C LH EXHAUST VALVE
- D RH EXHAUST VALVE
- E DRAIN VALVE
- F INLET AIR VALVE (OPTION-0)
- HRM HOURS RUN METER

P&I Diagram

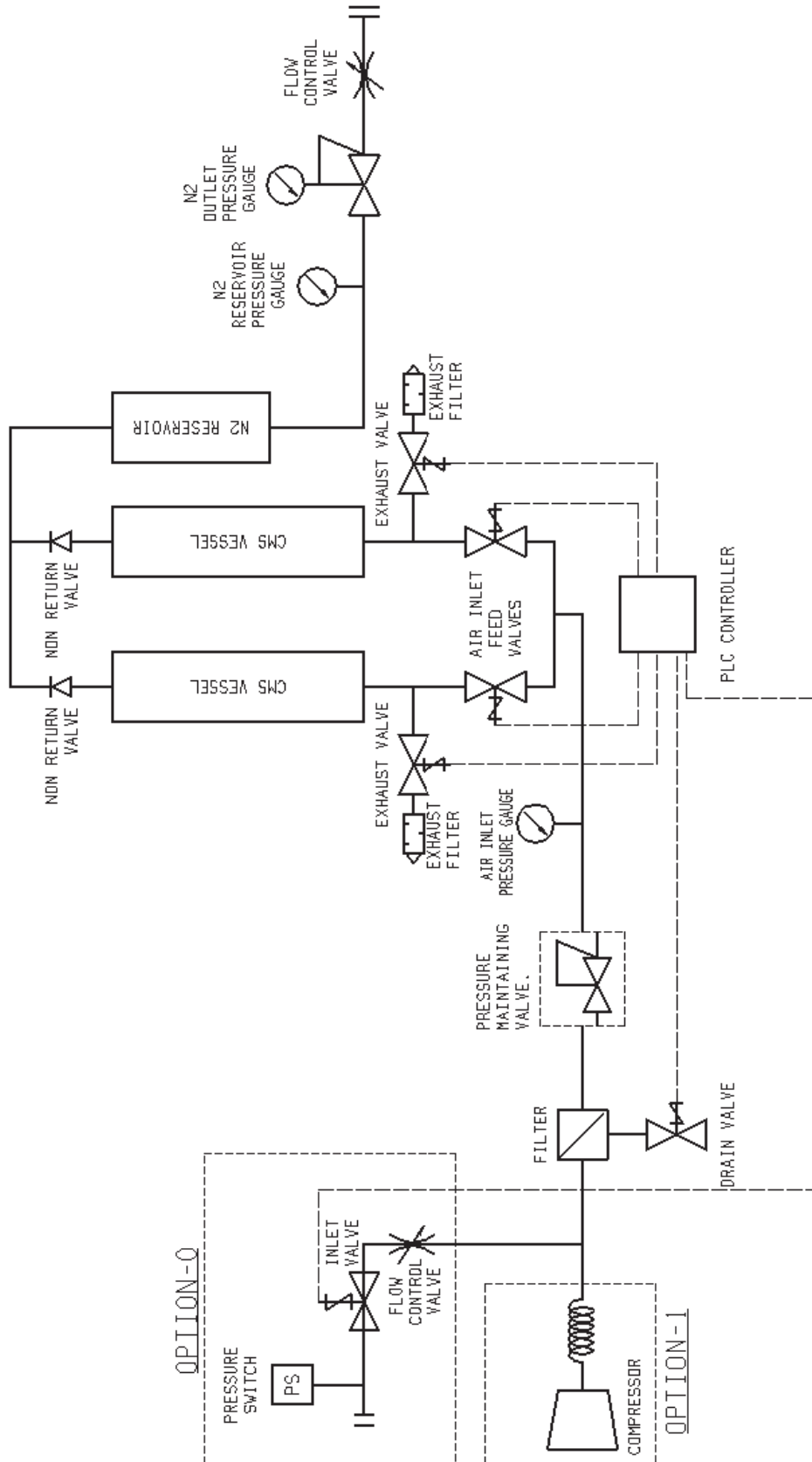

8 - WARRANTY

This warranty applies to NITROGEN GENERATORS and associated parts (the Equipment) manufactured and supplied by **domnick hunter ltd (domnick hunter)**.

Use of the NITROGEN GENERATORS without the recommended inlet air quality (see page 18) or genuine parts will expressly invalidate the warranty.

Should the Equipment be defective as to materials or workmanship, **domnick hunter** warrants that it will remedy such defect. Where the Equipment is a NITROGEN GENERATOR, the warranty period will be 12 months from date of commissioning or 18 months from date of manufacture, whichever is the earlier. In the case of Equipment other than a NITROGEN GENERATOR the warranty period shall commence from the date of despatch. Should any defect occur during the warranty period and be notified in writing to **domnick hunter** or its authorised distributor within the said period, **domnick hunter** will, as its sole option, remedy such defect by repair or provision of a replacement part, provided that the Equipment has been used strictly in accordance with the instructions provided with each item of Equipment and has been stored, installed, commissioned, operated and maintained in accordance with such instruction and with good practice. **domnick hunter** shall not be under any liability whatsoever under the warranty, if, before giving notification in writing to **domnick hunter** as aforesaid, the Customer or any third party meddles, interferes, tampers with or carries out work whatsoever (apart from normal maintenance as specified in the said instructions) in relation to the Equipment or any part thereof.

Any accessories, parts and equipment supplied by **domnick hunter** but not manufactured by **domnick hunter** shall carry whatever warranty the manufacturer has given **domnick hunter** providing it is possible for **domnick hunter** to pass on such warranty to the customer.

To claim under the warranty, the goods must have been installed and continuously maintained in the manner specified in the ICOM. Our product support engineers are qualified and equipped to assist you in this respect. They are also available to make repairs that may become necessary in which event they will require an official order before carrying out the work. If such work is to be the subject of a warranty claim, the order should be endorsed for consideration under warranty.

Where Equipment is sold outside the UK mainland direct to the end user the warranty will cover parts only. Any substitution of parts not manufactured or approved by **domnick hunter** will expressly invalidate the warranty.

DECLARATION OF CONFORMITY 89/329/EEC 89/336/EEC 73/23/EEC		GB
Name of manufacturer or supplier: domnick hunter ltd		
Address: Dukesway, Team Valley Trading Estate, Gateshead, Tyne and Wear, England, NE11 0PZ		
Description of Product:	Laboratory Nitrogen Generator	
Model Number UHPLCMS12, UHPICP5001, UHPN5001 UHPLCMS18, UHPICP5000, UHPN5000		
Place of issue: GATESHEAD, TYNE AND WEAR, ENGLAND		
Name of authorised representative: DAVID KEAY		
Position of authorised representative: MANAGING DIRECTOR (GAS GENERATION)		
Declaration: I declare that, as the authorised representative, the above information in relation to the supply/manufacture of this product is in conformity with the stated standards and other related documents following the provisions of the 89/392/EEC 89/336/EEC 73/23/EEC directives.		
Signature of authorised representative		
p u r e i n n o v a t i o n		

a member of the domnick hunter group plc

10 - NOTES



domnick hunter limited

Dukesway Team Valley Trading Estate

Gateshead Tyne and Wear England NE11 0PZ

Tel: +44 (0)191 402 9000 Telefax: +44 (0)191 497 1216/402 9015

e-mail gasgen@domnickhunter.com

Web Site: www.domnickhunter.com



domnick hunter pty ltd

Boronia Victoria Australia
Tel: +61 (0)3 9762 9922
Telefax: +61 (0)3 9762 9911



domnick hunter Canada inc

Ontario Canada
Tel: +1 905 820 7146
Telefax: +1 905 820 5463



domnick hunter (China) Beijing Office

Beijing China
Tel: +86 10 646 33523
Telefax: +86 10 646 33521

domnick hunter (China) Shanghai Office

Shanghai China
Tel: +86 21 5240 0220
Telefax: +86 21 628 38311



domnick hunter Skandinavia

Slangerup Denmark
Tel: +45 (0)47 38 0644
Telefax: +45 (0)47 38 0643



domnick hunter France SA

Villefranche sur Saône France
Tel: +33 (0)4 74 62 34 51
Telefax: +33 (0)4 74 62 35 44



domnick hunter GmbH

Krefeld Germany
Tel: +49 (0)2151 83660
Telefax: +49 (0)2151 395779



PT domnick hunter Indonesia

Jakarta 14240 Indonesia
Tel: +62 21 458 40488
Telefax: +62 21 452 4323



domnick hunter Nihon

Kobe Japan
Tel: +81 (0)78 391 8055
Telefax: +81 (0)78 391 8056

domnick hunter Nihon

Yokohama Japan
Tel: +81 (0)45 250 1522
Telefax: +81 (0)45 250 1523



domnick hunter-RL (Malaysia) SDN BHD

Petaling Jaya Malaysia
Tel: +60 3 733 3415
Telefax: +60 3 735 1699



domnick hunter Group Pte Ltd

Singapore
Tel: +65 744 4088
Telefax: +65 744 9959



domnick hunter Iberica

Barcelona Spain
Tel: +34 (0)93 351 4807
Telefax: +34 (0)93 351 7102



domnick hunter SweTec AB

Gothenburg Sweden
Tel: +46 (0)31 748 0610
Telefax: +46 (0)31 748 0621



domnick hunter-RL (Thailand) Co Ltd

Bangkok Thailand
Tel: +66 2 255 5305-8
Telefax: +66 2 255 5340



domnick hunter Ltd

Gateshead England
Tel: +44 (0)191 402 9000
Telefax: +44 (0)191 497 1216
e-mail: gasgen@domnick.co.uk
Web site: www.domnickhunter.com



domnick hunter inc

Charlotte NC 28269 USA
Tel: +1 704 921 9303
Telefax: +1 704 921 1960
Toll Free: +1 800 345 8462