

# **CRYOMECH**

## **Model PT405**

# **Cryogenic Refrigerator**

### **INSTALLATION, OPERATION AND ROUTINE MAINTENANCE MANUAL**

INCLUDES CP950 COMPRESSOR PACKAGE

Revision Date 4/22/2005

The information contained in this document is believed to be accurate and reliable as of the time of its publication. However, Cryomech, Inc. cannot accept any responsibility (financial or otherwise) that may result from the use or misuse of the information contained in this document. Except as expressly contained in this document, there are no other warranties granted or extended by the manufacturer.

Cryomech, Inc. reserves the right to add, change, modify or delete any or all information contained herein without prior written notice. Revisions to this document may be issued at the time such changes and/or deletions occur.

Any duplication of this manual or any of its parts without expressed written permission from Cryomech, Inc. is expressly prohibited.

Correspondence concerning this document should be forwarded to:

Customer Service Department  
Cryomech, Inc.  
113 Falso Drive  
Syracuse, NY 13211 USA

Telephone (315) 455-2555  
FAX: (315) 455-2544

specs@cryomech.com

[www.cryomech.com](http://www.cryomech.com)

2/2005

## Table of Contents

1	Section 1: Overview .....	5
1.1	Cryogenic refrigeration system .....	5
1.1.1	General description.....	5
1.1.2	Features and benefits of the Cryomech PT405.....	5
1.2	Cryomech PT405 manual .....	6
1.2.1	Organization of the manual.....	6
1.2.2	Related documents .....	6
1.3	Glossary .....	7
1.3.1	Definitions .....	7
1.3.2	Acronyms .....	8
1.4	Cryomech Contact Information .....	8
2	Section 2: Warranty.....	10
2.1	Statement of warranty.....	10
2.2	Conditions that can void the warranty.....	10
3	Section 3: Safety .....	12
3.1	Safety and information symbols.....	12
3.1.1	Equipment symbols.....	12
3.1.2	Icons in the manual.....	12
3.2	Warnings and cautions.....	13
3.2.1	Technical specifications .....	13
3.2.2	Shipping.....	13
3.2.3	Installation.....	13
3.2.4	Section 7 Operation .....	16
3.2.5	Section 8 Routine maintenance.....	17
4	Section 4: Specifications .....	19
4.1	Intended use of equipment .....	19
4.2	Technical specifications .....	19
4.2.1	Weights and dimensions.....	19
4.2.2	Cooling water specifications .....	20
4.2.3	Electrical specifications.....	22
4.2.4	Fuse Specifications.....	22
4.2.5	Operating parameters.....	23
4.3	Description of compressor .....	24
4.3.1	Front panel interfaces .....	24
4.3.2	Internal safety devices .....	26
5	Section 5: Inspection and Unpacking.....	27
5.1	Inspection of crate.....	27
5.2	Unpacking .....	27
5.3	Inspection of equipment.....	28
5.4	Returning a system to Cryomech.....	28
6	Section 6: Installation .....	30
6.1	Cold head installation.....	30
6.1.1	Unpack the cold head from shipping box.....	30
6.1.2	Initial preparation of the cold head.....	31
6.1.3	Optimal installation of temperature sensors (optional) .....	31
6.1.4	Installation of heaters (optional).....	32
6.1.5	Mounting the radiation shield (optional).....	32
6.2	Compressor installation.....	32
6.2.1	Step 1 -- Prepare the compressor package location .....	32
6.2.2	Step 2 – Connect the water lines to the compressor (water-cooled models only) ..	33
6.2.3	Step 3 – Connect the helium flex lines to the cold head and compressor package	33
6.2.4	Step 4 – Connect the cold head motor cord .....	35
6.2.5	Step 5 – Connect the compressor package to the main power.....	35

6.2.6	Step 6 – Remove excess helium from the compressor package prior to running the system for the first time .....	36
6.2.7	Step 7 – Run the system for the first time.....	36
7	Section 7: Operation.....	39
7.1	Starting the system .....	39
7.1.1	Checks before operating.....	39
7.1.2	Startup procedure .....	39
7.2	Normal operation behavior.....	40
7.3	Recommended routine procedures.....	40
7.3.1	High and low pressure .....	41
7.3.2	Cold head temperature .....	41
7.3.3	Cooling water input and output (water cooled models only).....	41
7.4	Shutdown procedure .....	41
7.5	Disassembling the system for transport or storage .....	41
7.6	Troubleshooting .....	44
7.6.1	System will not start.....	44
7.6.2	System starts, no pressure fluctuation.....	44
7.6.3	System has shut itself down. Power switch light off .....	45
7.7	Contact Cryomech with Questions.....	45
7.7.1	Contact Information.....	45
8	Section 8: Routine Maintenance .....	46
8.1	Introduction .....	46
8.2	Cryorefrigerator system.....	46
8.2.1	Adjust helium pressure - vent excess helium .....	46
8.2.2	Adjust helium pressure - recharge helium .....	46
8.3	Compressor package.....	48
8.3.1	Replace the adsorber.....	48
8.3.2	Replace the air filter (air cooled models only) .....	49
8.4	Servicing the cold head.....	49
8.5	Other maintenance items .....	49
8.5.1	Cleaning.....	49
8.5.2	Replaceable fuses .....	50
8.5.3	Manufacturer only parts .....	50
8.5.4	Cord replacement details:.....	50
8.6	Service .....	51
8.6.1	Cryomech contact information:.....	51

## Figures

Figure 1:	Cooling Water Requirements.....	20
Figure 2:	Front panel of the CP950 Compressor package with all controls and connections labeled.....	24
Figure 3:	Schematic of the PT405 cold head .....	30
Figure 4:	Connecting the Aeroquip® on the high pressure flex line to the high-pressure connection on the cold head. ....	34
Figure 5:	Connecting Aeroquips® to or disconnecting Aeroquips® from the compressor package .....	34
Figure 6:	Color codes for 60 Hz and 50 Hz models .....	37
Figure 7:	Disconnecting Aeroquips® from the compressor package.....	42
Figure 8:	Disconnecting Aeroquips® from the cold head.....	43
Figure 9:	Helium recharging assembly.....	47
Figure 10:	Disconnecting the adsorber. ....	48
Figure 11:	Cold Head Line Drawing. ....	48
Figure 10:	Electrical Schematic of Cryorefrigerator.....	50

# 1 Section 1: Overview

This section provides an overview discussion of cryorefrigerators and of the PT405 in particular. It also provides an overview of this manual, including the organization, basic definitions of terms used and expansion of acronyms used in the manual.

## 1.1 Cryogenic refrigeration system

### 1.1.1 General description

The operation of a cryogenic refrigeration system is based on a closed-loop helium expansion cycle. A complete system consists of two major components: one is the compressor package, which compresses refrigerant and removes heat from the system; the other is the cold head, which takes refrigerant through one or more additional expansion cycles to cool it down to cryogenic temperatures. The refrigerant gas used in the Cryomech cryogenic systems is 99.999% pure helium. Flexible stainless steel lines called helium flex lines carry compressed helium from the compressor package to the cold head and carry low-pressure helium back.

The compressor package works as follows. An oil-lubricated compressor compresses the pure low-pressure helium that is returned from the cold head. The heat of compression is removed via a heat exchanger, and the oil from the compression process is removed in a series of oil separators and filters. The compressed helium is then fed to the cold head via the high-pressure helium flex line.

In the cold head, adiabatic expansion of the helium and further heat removal allows cooling to cryogenic temperatures. The low-pressure helium then returns to the compressor package via the low-pressure helium flex line.

### 1.1.2 Features and benefits of the Cryomech PT405

The Cryomech PT405 Cryorefrigerator features the CHPT405 Pulse Tube. It has been carefully designed and manufactured to provide years of trouble free service.

#### Primary features

The unique feature of pulse tubes, such as the PT405, is that the expansion of the helium in the cold head is done without a displacer or piston. This results in a cold head that has no moving parts at cryogenic temperatures, no seals and no motion of the regenerative materials.

#### Primary benefits

- Very low vibration
- High reliability
- Long mean time between maintenance
- Reduced magnetic fluctuation from rare earth materials
- Lower costs of operation and maintenance

## 1.2 Cryomech PT405 manual

This manual covers the PT405 cryorefrigerator that consists of the CHPT405 cold head, the CP950 compressor package, a cold head motor cord and a set of helium flex lines.

It is important that you review this manual carefully before beginning the installation process.

### 1.2.1 Organization of the manual

The main body of the manual provides a detailed discussion of everything you will need in order to install and operate the Cryomech PT405 cryorefrigerator and to perform routine maintenance. It is divided into 8 sections. Illustrations accompany the discussion as needed for clarification. Additional information will be in the appendix.

Numbered lists labeled with 1), 2), etc and lettered lists labeled with a., b., etc. are used for sequential actions that must be performed in the order listed. Lists for which order is not important are bulleted, using solid or hollow bullets.

The manual contains essential information for the safe and effective operation of the Cryomech PT405. Sections 2 and 3 clearly lay out all safety precautions you should take and also explain the ways in which you might inadvertently void your warranty by doing something that would damage the system.

Sections 5 through 8 provide complete step-by-step instructions on the handling of your PT405, from inspection of the packing crate through routine maintenance. Each safety precaution is also shown in these sections in every place where observing the caution or warning is important.

- Section 1: Overview (including definitions and acronyms)
- Section 2: Warranty
- Section 3: Safety considerations
- Section 4: Specifications
- Section 5: Inspection and unpacking
- Section 6: Installation
- Section 7: Operation
- Section 8: Routine maintenance
- Appendix: CAD drawings of the cryorefrigerator and other information

### 1.2.2 Related documents

#### Technical manual

A separate detailed technical manual will be available by contacting Cryomech. This manual covers the theory behind cryorefrigerators, and supplies detailed information on optimizing instrumentation and insulation of cold heads for maximum performance.

## 1.3 Glossary

### 1.3.1 Definitions

The terms defined below are used with precision in the manual. For example, distinction is made between the (cryorefrigerator) system, the (compressor) package, and the (compressor) module.

The terms are in alphabetical order, and italicized terms within the definitions are terms that are also defined in this section.

#### Aeroquip® Couplings:

The term "Aeroquip® couplings" is used generically to describe the self-sealing fittings that connect components, e.g. that connect *helium flex lines* to the *compressor package* and *helium flex lines* to the *cold head*.

#### Category II Installation:

Category II refers to the potential for transient over-voltage conditions in the mains power connection to the equipment. See IEC 664, Sub-clause 5.6 for further details.

#### Closed Loop System:

This refers to a cryogenic *system* that has no helium loss because the helium is cycled through a closed loop. The advantage of such a *system* is that there is no need to add helium.

#### Cold Head:

The cold head is an expansion device, which is capable of reaching *cryogenic temperatures*. In the AL or GB systems the cold head is a *Gifford-McMahon* style unit. In the PT series systems the cold head is a *Pulse Tube* style unit (see Figure 4 in section 6.1.1 for more information).

#### Cold Head Motor Cord

The cold head motor cord is pre-wired and fitted with electrical connectors on each end that attach to the *cold head* and *compressor package*. The cold head motor cord provides electrical power from the *compressor package* to the *cold head* motor.

#### Compressor Module:

Located inside the *compressor package*, the compressor module is an oil-lubricated commercial compressor that compresses low-pressure helium to the necessary high pressure.

#### Compressor Package:

The compressor package houses the *compressor module* and all other components that compress and purify helium and that provide system safety control. The compressor package compresses the low-pressure helium returning from the cold head and provides clean high-pressure helium to the *cold head*.

#### Cryogenic Temperatures:

Temperatures lower than 120K or -153°C.

#### Cryorefrigerator (Cryocooler):

A cryorefrigerator is a cryogenic refrigeration *system* based upon a closed loop helium expansion cycle. It consists of a *compressor package*, *helium flex lines* and a *cold head* (expansion device).

### Cold Head Heat Exchanger:

The first and (if applicable, second stage) heat exchanger(s) on the cold head provide cooling at cryogenic temperatures by transferring heat to the helium within the system. (See Figure 4 in section 6.1.1.)

### Gifford-McMahon Cryorefrigerator

A Gifford-McMahon cryorefrigerator is a *cryorefrigerator* in which the *cold head* expands the helium using a displacer or piston.

### Helium Flex Lines:

The helium flex lines are corrugated stainless steel hoses that transport helium between the compressor package and the cold head.

### Nitrogen Flexible Lines or Flex Lines:

Nitrogen flex lines are corrugated stainless steel hoses that carry nitrogen. These lines only apply to Liquid Nitrogen Plant models.

### Pollution Degree 2:

Pollution degree 2 refers to the extent to which the local environmental conditions could affect the electrical safety of the system. See EN 61010 or UL 61010A for further details.

### Pulse Tube Cryorefrigerator:

A pulse tube cryorefrigerator is a *cryorefrigerator* in which the *cold head* expands the helium using a pulse tube instead of a displacer or piston.

### System:

The term "system" is used as a synonym for *cryorefrigerator*. It consists of a *compressor package*, *helium flex lines* and *cold head*.

## 1.3.2 Acronyms

The following acronyms are used in the text and provided here for convenient lookup.

BSPP British Standard Parallel Pipe

BSPF British Standard Pipe Female

FPT Female Pipe Thread

GPM Gallons Per Minute

LPM Liters Per Minute

MPT Male Pipe Thread

OFHC Oxygen-Free High Conductivity (describes a form of Copper)

PSIG Pounds per Square Inch Gauge

## 1.4 Cryomech Contact Information

Cryomech, Inc.

113 Falso Drive

Syracuse, NY 13211

Phone: (315) 455-2555

Fax: (315) 455-2544



Email: [specs@cryomech.com](mailto:specs@cryomech.com)

Website: [www.cryomech.com](http://www.cryomech.com)

## 2 Section 2: Warranty

---

### 2.1 Statement of warranty

Provided that the customer installs, operates and maintains this cryorefrigerator according to the specifications and procedures set forth in this manual, Cryomech, Inc. extends a warranty on all parts and workmanship for a period of three (3) years or 12,000 operating hours, whichever comes first. This warranty covers all non-user serviceable components of the compressor package, the cold head and the helium flex lines. The warranty does not cover user-serviceable parts.

If found to be defective and in accordance with the terms of the limited warranty, Cryomech will provide warranty replacement parts at no cost to the customer. Customers are responsible for all shipping and handling charges associated with warranty repair.

The PT405 cold head is also warranted for the same three (3) years or period of 12,000 operating hours to deliver the specified temperatures and cooling capacities.-

### 2.2 Conditions that can void the warranty

- Do not apply heat directly to the cold head (e.g. soldering anything to the heat exchanger(s), see Figure 4). Doing so will damage the cold head and void the warranty. The warranty will not cover heating of the cold head over 325K (125°F, 52°C). Section 6.1.2
- The entire section on cold head installation should be reviewed before installing and operating the cold head. The entire section on compressor installation should be reviewed before installing and operating the compressor package. Failure to follow installation directions could result in loss of warranty rights. See sections 6.1 and 6.2.
- A voltage deviation of more than 10% above or below the voltage rating can cause compressor motor overheating and possible failure. Indications of operation outside that voltage range will void the compressor warranty. See section 7.1.1.
- Helium added to the system must be 99.999% pure. Contamination of the helium by other gases is a common cause of premature failure and, unless resulting from a system failure, is not covered by the warranty. See sections 6.2.6 and 8.2.2.
- Running the compressor package in reverse will void the warranty. If the power cord is not wired properly the compressor will run in reverse and there will be no pressure differential on the pressure gauges. Turn the system off immediately. See section 6.2.7 and follow the instructions there.
- Never wet either part of the system. Water getting into the system will void the warranty.
- Operating the cold head in a magnetic field of greater than 500 gauss will void the warranty. See sections 6.1 and 7.1.1.
- (Water-cooled models only.) If water that does not meet the cooling water specifications in section 4 is introduced into the system, even for cleaning purposes, it will void the warranty. See section 6.2.2.
- There are no user-serviceable parts in the cold head. Cryomech requires that all service to a Pulse Tube Cold Head be performed by Cryomech certified technicians. *Attempting to disassemble the Pulse Tube style cold head will void the warranty.* See section 8.4.

- Because the tubes in the cold head must have very thin walls for cryogenic performance, extreme care must be taken when handling the cold head. *The warranty will not cover dented or bent tubes.* See section 6.1 and 6.1.2.
- In some applications, heavy components must be mounted to the cold surfaces. With the cold head oriented vertically, the maximum allowable load is 22 lb or 10 kg on the 1st stage heat exchanger and (if the cold head is a two stage unit) 11 lb or 5 kg on the 2nd stage heat exchanger (see Figure 4, section 6.1.1). If your application requires a heavier load or an orientation other than vertical with a load, please contact Cryomech. *An excessive load on the cold head can damage the tubes. This type of damage is not covered under the warranty.*
- If the bolt pattern on either heat exchanger needs to be changed, you must consult Cryomech first to learn how to prevent damage to the cold head. *Holes drilled without prior approval from Cryomech will void the warranty.*
- *Operation of the cryorefrigerator in any situation that does not meet the specifications in section 4.2 will void the warranty.* If you plan to operate the system outside any of the specified conditions, contact Cryomech. See section 4.2.

## 3 Section 3: Safety

### 3.1 Safety and information symbols

#### 3.1.1 Equipment symbols

The safety and information symbol stickers placed on Cryomech PT405 cryorefrigerators are defined below.



Alternating current. The symbol signifies that alternating current is present.



Internal ground. This symbol represents an internal protective grounding terminal. Such a terminal must be connected to earth ground prior to making any other connections to the equipment.



Warning Icon. Refer to the documents that accompany the equipment.



The CE icon is placed on a product if the product has been tested for and meets the safety standards set by the European Community. CE stands for Communauté Européenne.



Power switch. This symbol designates an in/out or push/push switch.



Read the manual or handbook sign. When this symbol is found on a piece of equipment, the user should read the whole manual before starting installation or use. This symbol is found on the compressor package.

#### 3.1.2 Icons in the manual

Definitions of Warning and Caution and Information icons in the manual



Warning Icon. A warning message is used when failure to observe instructions or precautions could result in injury or death to humans.



Electrical Warning Icon. An electrical warning message is used when failure to observe instructions or precautions could result in electrical shock or burns to humans



Caution Icon. A caution message is used when failure to observe instructions or precautions could result in significant damage to equipment and/or facilities.



Information Icon. The accompanying message contains information to aid the operator in obtaining the best performance from the equipment or other important information that does not involve danger to equipment or humans.

## 3.2 Warnings and cautions

Warnings and cautions for the PT405 cryorefrigerator system are listed here by subsystem. The same warnings and cautions appear in the appropriate places in the unpacking, installation, operation and routine maintenance sections of this document.

### 3.2.1 Technical specifications

#### Section 4.2 Technical specifications

##### **IMPORTANT**

*Operation of the cryorefrigerator in any situation that does not meet the specifications in this section will void the warranty. If you plan to operate the system outside any of the specified conditions, contact Cryomech.*

### 3.2.2 Shipping

#### Section 5.1 Inspection of crate (receiving)

##### **IMPORTANT**

If there is any visible damage, do not open or unpack the packing crate before you contact Cryomech.

#### Section 5.4 Returning a system to Cryomech

##### **IMPORTANT**

Use the original cold head box to minimize the likelihood of damage during shipping.

### 3.2.3 Installation

#### Section 6.1 Cold head installation

##### **IMPORTANT**

*Failure to follow these installation guidelines could result in voiding the warranty.*



##### **CAUTION**

Because the tubes in the cold head must have very thin walls for cryogenic performance, extreme care must be taken when handling the cold head. *The warranty will not cover dented or bent tubes.*

**CAUTION**

*Operating the cold head in a magnetic field of greater than 500 gauss will void the warranty.*

**Section 6.1.2 Initial preparation of the cold head****CAUTION**

Because the tubes in the cold head must have very thin walls for cryogenic performance, extreme care must be taken when handling the cold head. Take special care to not bend the tube assemblies. *Bent tubes will violate the system's warranty.*

**CAUTION**

Do not apply heat directly to the cold head (e.g. soldering anything to the heat exchanger(s), see Figure 4) Doing so will damage the cold head and void the warranty. *The warranty will not cover heating of the cold head over 325K (125°F, 52°C).*

**Section 6.2 Compressor package installation****IMPORTANT**

*Failure to follow these installation guidelines could result in voiding the warranty.*

**Section 6.2.1 Step 1 -- Prepare the compressor package location****WARNING**

The compressor package must be positioned to provide easy access to the front-panel mounted circuit breaker.

**Section 6.2.2 Step 2 – Connect the water lines to the compressor (water cooled models only)****CAUTION**

Cooling water must meet the requirements in section 4.2. If water that does not meet the cooling water specifications in section 4.2 is introduced into the system, even for cleaning purposes, it will void the warranty.

**CAUTION**

Do not apply heat to the cooling water inlet and outlet connectors located on the front panel of the compressor (see Figure 3).

**Section 6.2.3 Step 3 Connect the helium flex lines to the cold head and compressor package****CAUTION**

Follow the procedure carefully when connecting and disconnecting the helium flex lines. Failure to follow the procedure can cause accidental coupling disassembly, destruction of the sealing O-ring, and helium loss.

**WARNING**

Never remove the Aeroquip® couplings from the helium flex lines without first relieving the helium charge in the line to acceptable levels. The pressure in the hose can blow off the coupling with sufficient force to cause injury.

**Section 6.2.5 Step 5 – Connect the compressor to main power****IMPORTANT**

A voltage deviation of more than 10% above or below the voltage rating can cause compressor motor overheating and possible failure. *Indications of operation outside that voltage range will void the compressor warranty.*

**IMPORTANT**

*Be sure to follow all local electrical codes and guidelines.*

**WARNING**

One lead of the compressor package is grounded. Never bypass this ground or attach the compressor package to an ungrounded circuit. A dangerous electrical hazard will develop.

**Section 6.2.6 Step 6 – Remove excess helium from the compressor package prior to running the system for the first time****IMPORTANT**

The system is shipped from the factory with excess helium in order to allow for some loss when assembling system components. *Complete this step ONLY if the actual system pressure exceeds the pressure indicated in Item 1, below.*

**IMPORTANT**

Helium added to the system must be 99.999% pure. Contamination of the helium by other gases is a common cause of premature failure and, *unless resulting from a system failure, is not covered by the warranty.*

### **Section 6.2.7 Run the system for the first time**



#### **CAUTION**

*Running the compressor package in reverse will void the warranty. If the power cord is not wired properly the compressor will run in reverse and there will be no pressure differential on the pressure gauges. Turn the system off immediately. Follow the instructions in section 6.2.7 to rewire the power plug correctly.*



#### **CAUTION**

You must turn off the compressor package immediately in order to prevent damage to the compressor package. Then perform step 7 below.

## **3.2.4 Section 7 Operation**

### **Section 7.1.1 Checks before operating**



#### **CAUTION**

A voltage deviation of more than 10% above or below the voltage rating can cause compressor motor overheating and possible failure. *Indications of voltage operation outside that range will void the compressor warranty.*



#### **CAUTION**

*Operating the cold head in a magnetic field of greater than 500 gauss will void the warranty.*

### **Section 7.1.2 Startup procedure**



#### **CAUTION**

*Running the compressor package in reverse will void the warranty. If the power cord is not wired properly the compressor will run in reverse and there will be no pressure differential on the pressure gauges. Turn the system off immediately. Follow the instructions in section 6.2.7 to rewire the power plug correctly.*

### **Section 7.3 Recommended routine procedures**

#### **INFORMATION**

It is helpful to monitor the PT405 cryorefrigerator daily in order to detect changes in performance early. These changes can signify degradation in performance that could result from the beginning of a problem that requires attention.



### **Section 7.5 Disassembling the system for transport or storage**

#### **IMPORTANT**

Do not continue with the remaining steps until the cold head temperature has risen above 150K. If the cold head is disconnected from the system while below 150K, helium will expand within the cold head as it warms, escape through the pressure relief valve and require the user to recharge the system with helium before it would again operate properly.

## **3.2.5 Section 8 Routine maintenance**

### **Section 8.2.1 Vent helium**



#### **CAUTION**

Venting more than 5 PSIG (.34 bar) of helium per minute will lead to improper oil migration within the system. If this condition occurs, factory service will be required.

### **Section 8.2.2 Recharge helium**



#### **CAUTION**

When adding helium, the helium must be 99.999% pure. Contamination by other gases will result in the freezing of the contaminant gases in the cold head because their freezing temperature is much higher than that of helium. Contaminants in the helium charge will severely degrade the cold head's function and it will require factory servicing.

*Contamination of the helium by other gases is a common cause of premature failure and, unless resulting from a system failure, is not covered by the warranty.*



#### **CAUTION**

No more than 5 PSIG (.34 bar) of gas should be added per minute to prevent internal oil contamination to the system. If such contamination occurs, factory service will be required.

### **Section 8.3.1 Replace the adsorber**



#### **CAUTION**

At no time should the Aeroquip® couplings be removed from the adsorber when replacing the adsorber. Replacement can be completed without relieving system pressure since the adsorber is equipped with Aeroquip® couplings for sealed removal.

**Section 8.5.1 Cleaning****CAUTION**

Never remove an Aeroquip® coupling from the helium flex line.

**Section 8.5.4 Cord replacement - power cord****WARNING**

One lead of the compressor system is grounded. Never bypass this ground or attach the compressor to an ungrounded circuit. A dangerous electrical hazard will develop.

## 4 Section 4: Specifications

### 4.1 Intended use of equipment

The PT405 cryorefrigerator system is used for cooling to cryogenic temperatures. Current clients include research laboratories and universities as well as manufacturers of MRI and NMR superconducting magnets as well as other types of equipment that require cryogenic temperatures.

### 4.2 Technical specifications

Following are the detailed technical specifications for the PT405 cold head and the CP950 compressor package.

#### **IMPORTANT**

*Operation of the cryorefrigerator in any situation that does not meet the specifications in this section will void the warranty. If you plan to operate the system outside any of the specified conditions, contact Cryomech.*

#### 4.2.1 Weights and dimensions

Parameter	Value	
Cold Head Weight	32 lb	14.5 kg
Cold Head Dimensions	See Cold Head line drawing (Figure 12)	
Compressor Package Weight, Air-Cooled	387 lb	176 kg
Compressor Package Weight, Water-Cooled	262 lb	119 kg
Compressor Package Dimensions, Air-Cooled (L x W x H)	23 X 21 X 46 in	58 X 53 X 117 cm
Compressor Package Dimensions, Water-Cooled (L x W x H)	23 X 21 X 26 in	58 X 53 X 66 cm

## 4.2.2 Cooling water specifications

Parameter	Value	
Cooling water: minimum flow @ max temperature See Chart 1 for details.	1.6 GPM @ 80 F	6.0 LPM @ 27 C
Maximum inlet pressure	110 PSIG	7.5 bar
Alkalinity	5.8 < pH < 8.0	5.8 < pH < 8.0
Calcium Carbonate	Concentration < 80 PPM	Concentration < 80 PPM

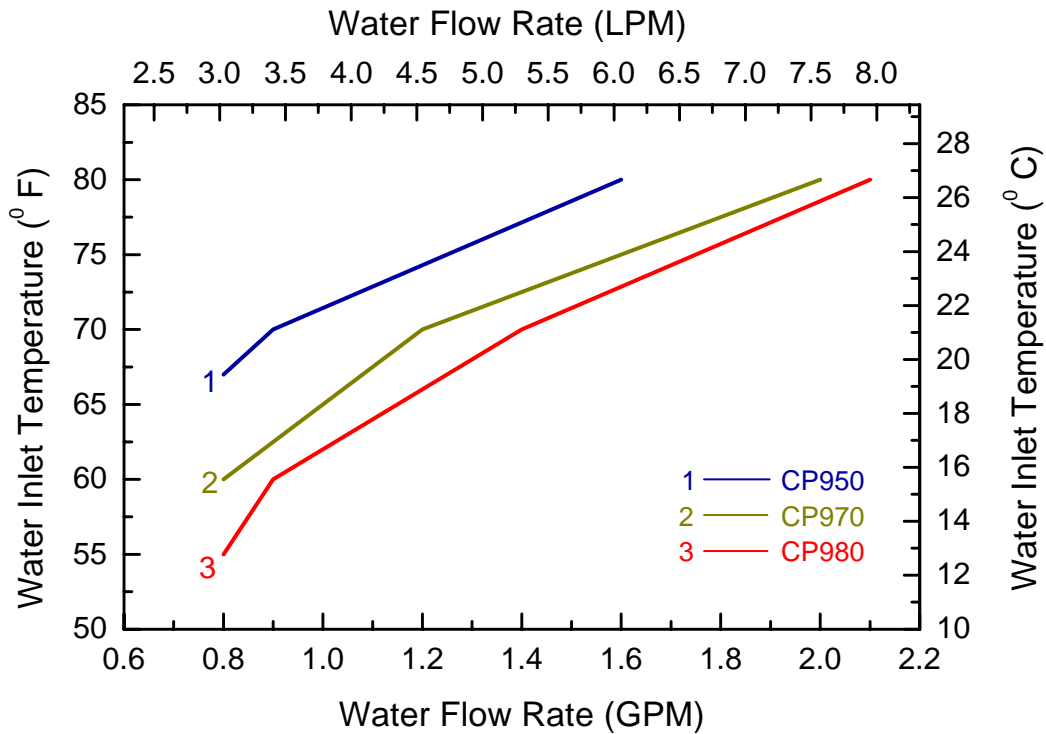
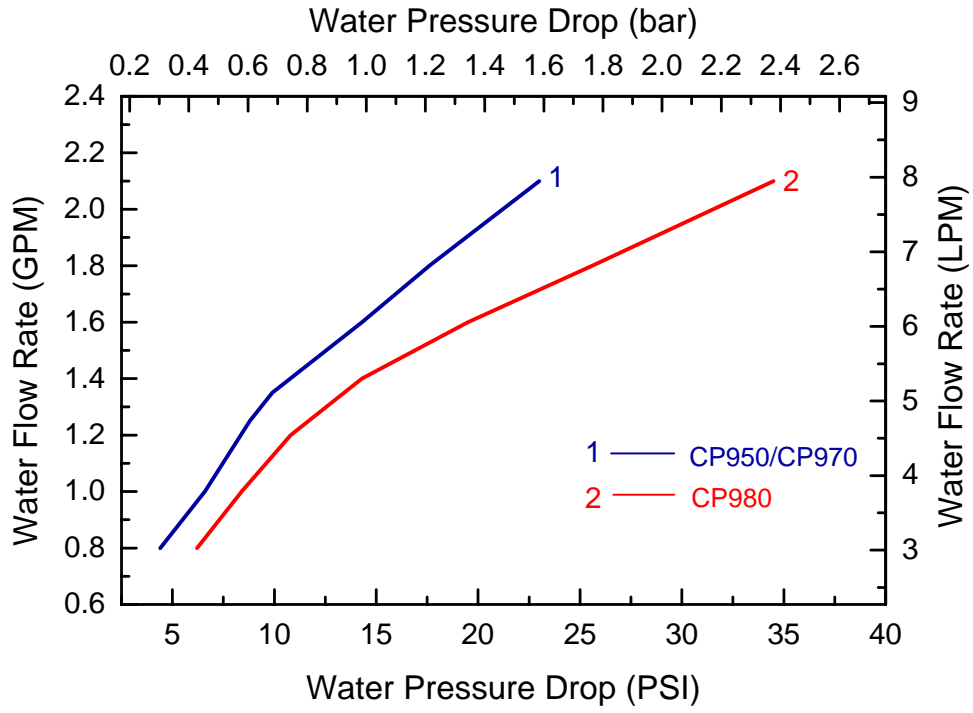

Figure 1: Cooling Water Requirements



**Figure 2: Cooling Water Pressure Drop**

### 4.2.3 Electrical specifications

Parameter	220/230 Volt 60 Hz Model	460 Volt 60 Hz Model	200/220 Volt 50 Hz Model	380/420 Volt 50 Hz Model
Nominal voltage	220/230 VAC	460 VAC	200/220 VAC	380/420 VAC
Operating voltage range	200 - 253 VAC	414 - 506 VAC	180 - 242 VAC	342 - 462 VAC
Frequency	60 Hz	60 Hz	50 Hz	50 Hz
Phase	3	3	3	3
Water Cooled <i>Input Power</i> Maximum: Steady state:	6.3 kW 4.8 kW	6.3 kW 4.8 kW	6.3 kW 4.8 kW	6.3 kW 4.8 kW
Current	19 A	9.0 A	24.5 A	13 A
Air Cooled <i>Input Power</i> Maximum: Steady state:	kW 5.3 kW	kW 5.3 kW	kW 5.3 kW	kW 5.3 kW
Current	A	A	A	A
Dedicated circuit breaker	40 A	25 A	40 A	25 A
Mains supply voltage fluctuations	Up to $\pm 10\%$ of the nominal voltage	Up to $\pm 10\%$ of the nominal voltage	Up to $\pm 10\%$ of the nominal voltage	Up to $\pm 10\%$ of the nominal voltage

### 4.2.4 Fuse Specifications

Transformer	Fuse*	220/230 Volt 60 Hz	460 Volt 60 Hz	200/220 Volt 50 Hz	380/420 Volt 50 Hz
250 VA	Primary	2.5A	1.25A	2.5A	1.25A

\*All fuses are 13/32" x 1-1/2", Type CC time delay fuses, rated for 600V.

#### 4.2.5 Operating parameters

Parameter	Value	
Ambient temperature range	45 to 100 °F	7 to 38 °C
System helium pressure	220 ± 5 PSIG @ 60 Hz (15.2 ± .34 bar @ 60 Hz)	(190 ± 5 PSIG @ 50 Hz) 13.1 ± .34 bar @ 50 Hz
Acceptable location	Indoors only	Indoors only
Maximum altitude for use	6560 ft	2000 m
Environment	Pollution Degree 2	Pollution Degree 2
Installation	Category II	Category II
Maximum relative humidity	80% for T < 88°F Decreasing linearly to 50% at 104°F.	80% for T < 31°C Decreasing linearly to 50% at 40°C.
Maximum sound level	dBA at 1 meter	dBA at 1 meter
Cold head 1 <sup>st</sup> stage maximum load	22 lb	10 kg
Cold head 2 <sup>nd</sup> stage maximum load	11 lb	5 kg

### 4.3 Description of compressor

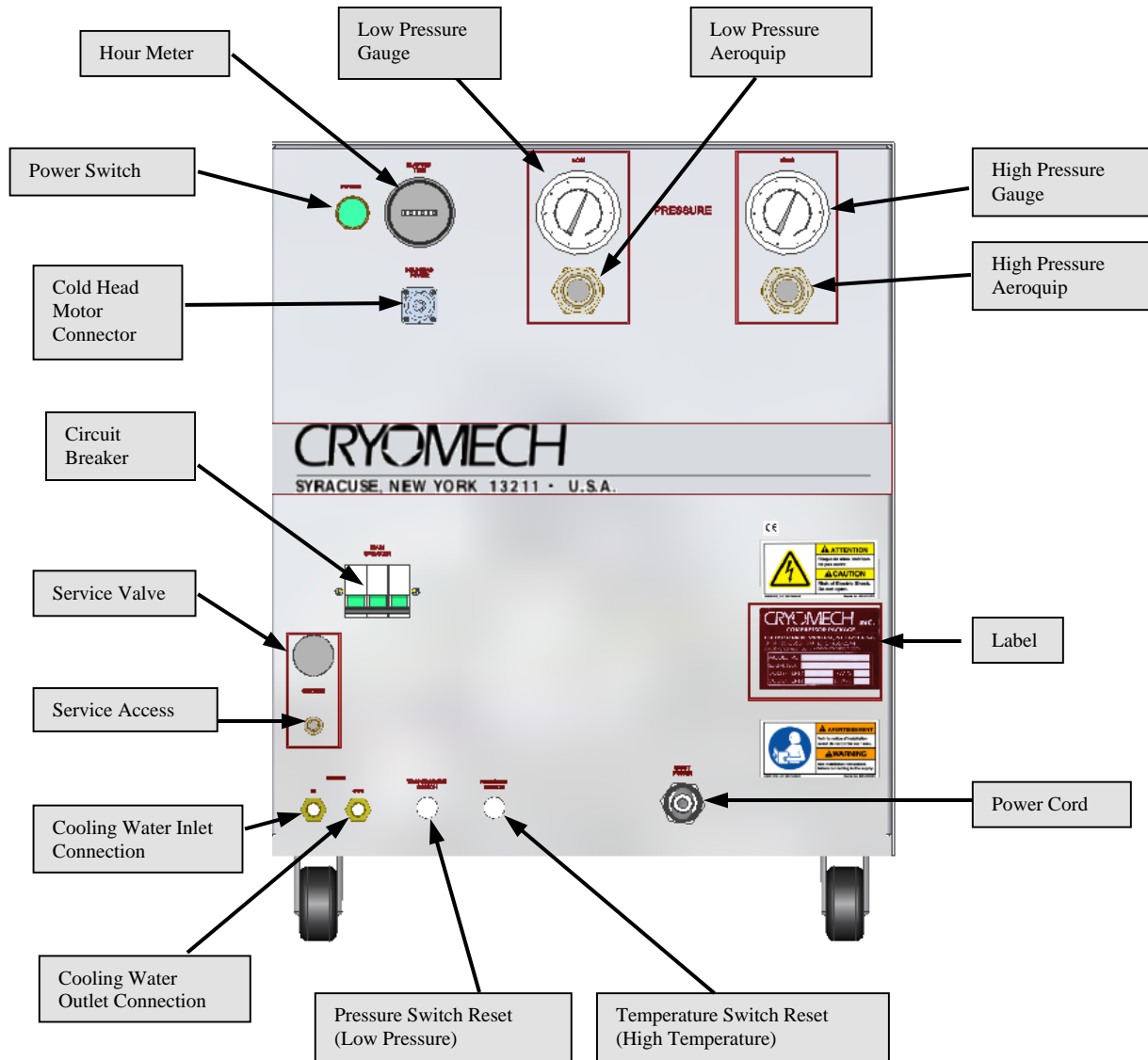

**Figure 3: Front panel of the CP950 Compressor package with all controls and connections labeled.**

#### 4.3.1 Front panel interfaces

This section describes the function of all operator interfaces on the front panel of the CP950 compressor package, including switches and valves. It also describes the functions of all connectors, electrical cords and gauges on the front panel.

##### Low-Pressure Aeroquip®

The low-pressure helium flex line (not shown) fastens to the low-pressure Aeroquip® that returns helium gas from the cold head to the compressor package.



**Low-Pressure Gauge**

The low pressure gauge displays the pressure of the helium gas that is being returned to the compressor package. When the compressor package is off and the complete system is at room temperature, the gauge should read  $220 \pm 5$  PSIG ( $15.2 \pm .34$  bar) for 60 Hz models or  $190 \pm 5$  PSIG ( $13.1 \pm .34$  bar) for 50 Hz models.

**High-Pressure Aeroquip®**

The high-pressure helium flex line (not shown) attaches to the high-pressure Aeroquip® that supplies compressed helium gas from the compressor package to the cold head.

**High-Pressure Gauge**

The high-pressure gauge displays the pressure of the compressed helium gas that is transported from the compressor package. When the compressor package is off and the complete system is at room temperature, , the gauge should read  $220 \pm 5$  PSIG ( $15.2 \pm .34$  bar) for 60 Hz models or  $190 \pm 5$  PSIG ( $13.1 \pm .34$  bar) for 50 Hz models.

**Hour Meter**

The hour meter is an elapsed time indicator located on the front panel near the power switch. The hour meter is used to keep track of times for routine servicing and part replacement, which are determined by the number of hours of active use.

**Power Switch**

The lighted, push button, power switch activates (starts) the entire system.

**Cold Head Motor Connector**

The cold head motor cord attaches to the cold head motor connector to provide power from the compressor package to the cold head motor.

**Circuit Breaker**

The front panel-mounted circuit breaker provides over-current protection for the cryorefrigerator and functions as a main power disconnect.

**Service Valve**

The service valve is the valve used to regulate the amount of helium being added to or released from the system.

**Service Access**

The service access is used in conjunction with the service valve for adding helium to or releasing helium from the system.

**Cooling Water Inlet Connection**

(Water-cooled models only) The cooling water inlet connection provides water to the compressor package from your facility to cool the compressor package during operation. The connector thread size is a 1/4 FPT.

The water must meet the specifications provided in the Cooling Water Specifications table in section 4.2.

**Cooling Water Outlet Connection**

(Water-cooled models only) The cooling water outlet connection carries heated water away from the compressor package after the water has been heated by cooling the compressor package during operation. The connector thread size is 1/4 FPT.

**Pressure Switch Reset (Low Pressure)**

The compressor package has a low-pressure shutdown switch that is set at  $35 \pm 5$  PSIG ( $2.4 \pm .34$  bar). The pressure switch manual reset button is located on the bottom of the front panel as shown in Figure 3.

**Temperature Switch Reset (High Temperature)**

The high temperature shutdown switch is set at 120°F (49°C). The high temperature manual reset button is located on the bottom of the front panel as shown in Figure 3. The temperature switch cannot be reset until the sensor has cooled by approximately 15°F (8.5°C).

**Power Cord**

The power cord supplies power from the wall to the entire system.

**4.3.2 Safety devices**

A number of safety switches and valves are located inside the compressor package and on the cold head. They operate automatically to protect the system from developing extreme conditions that can damage it. Most of them are totally transparent to the user. The ones you need to know about are described below.

**High-Pressure Atmospheric Relief Valve**

The compressor package high-pressure atmospheric relief valve is set at  $377 \pm 5$  PSIG ( $26 \pm .34$  bar). At pressures above 377 PSIG (26 bar) the relief valve will open automatically and relieve pressure to the atmosphere.

**Internal Motor Overload Switch**

An internal motor overload switch, located inside the compressor module, protects the system by sensing excessive current draw and temperature. This switch automatically resets itself after the compressor module cools to an acceptable level.

**Cold Head High Pressure Relief Valve**

The cold head high-pressure atmospheric relief valve is set at  $425 \pm 5$  PSIG ( $29.3 \pm .34$  bar). At pressures above 425 PSIG (29.3 bar) the valve will open automatically and relieve pressure to the atmosphere.

## 5 Section 5: Inspection and Unpacking

### 5.1 Inspection of crate

**IMPORTANT**

If there is any visible damage, do not open or unpack the packing crate before you contact Cryomech.

Be sure to note on the shipping documents any visible damage to the packing crate, including tip indicators that have been activated.

### 5.2 Unpacking

The system is packaged in a secure packing crate. The base of the packing crate is a pallet, to which the system is strapped. The walls of the crate are then placed around the system and attached to the pallet and each other with tension clips (Klimp® fasteners). After adding packing material as needed, the top is clipped onto the packing crate.

**Directions for unpacking:**

1. Remove the top of the packing crate by unfastening the Klimp® fasteners that fasten the top to the sides.
2. Check for tip indicators on the inside of the packing crate and notify Cryomech if interior tip indicators have been activated even though tip indicators on the outside were not.
3. Check for any visible signs of damage besides activated tip indicators.
4. Locate and remove the manual, and all other items that can easily be lifted out of the crate. The manual is packed in an envelope with the shipping documents.
5. Remove the sides of the packing crate packing container by unfastening the Klimp® fasteners that fasten the sides to the pallet.
6. Remove packing material and any straps that anchor items to the pallet.
7. Make sure that a place is prepared for the compressor package to sit (see directions in section 6 for installation).
8. Retain the cold head box with all cold head packing materials and the packing crate to use in the future if you need to ship the equipment to Cryomech.

**Specific directions for moving when unpacking**

- 1) Move the cold head separately from the compressor. The cold head is much more fragile than the compressor and needs to be treated with care.
- 2) The compressor package needs to be lifted off the pallet base and onto the floor with a fork truck or a hoist. Depending on the model of the compressor package, it's weight is between 262 and 387 lbs (between 119 and 176 kg). The compressor should not be tipped more than 5° at any time.
- 3) If the compressor package comes with castors installed, it can be rolled by hand after it is removed from the crate. Otherwise, it will need to be moved with a fork truck or a hoist.

## 5.3 Inspection of equipment

### Packing list

There is a packing list included with your system. The first step is to check that all parts listed on the packing list are included in the packing packing crate.

### Electrical cords

The power cord is sent without a plug on the end.

The cold head motor cord is completely pre-wired with connectors that attach to the cold head and compressor.

Inspect the cords for visible damage.

### Helium flex lines

Inspect the helium flex lines for any signs of damage.

### Cold head

Inspect the box that contains the cold head for any signs of physical damage. Remove the two bolts that secure the box cover. Check the cold head itself for any small dents on the tubes and for any large scratches. Retain the cold head box and packing material in case the cold head must be returned.

### Compressor package

There should be a tag on the front of the compressor package that states the pressure of each gauge and the ambient temperature at the time the package was packed. Check the pressure readings on both pressure gauges. If either gauge reads 5 PSIG (.34 bar) lower than the recorded value, contact Cryomech.

Look for dents, scratches or any signs of oil leaks.

### Spare parts and tools

Your Cryomech Cryorefrigerator system is shipped with a box of spare parts and a box of tools. The label on each box lists the contents included in that box.

## 5.4 Returning a system to Cryomech

### Preparation of cold head, compressor, and helium flex lines

- 1) Contact Cryomech for an RMA number and for additional detailed instructions on how to properly return system components.
- 2) Repackage the system:

#### **IMPORTANT**

Use the original cold head box to minimize the likelihood of damage during shipping.

- Using the original packing material, rewrap the cold head and place in the original cold head box. The original cold head box and packing materials were designed to protect the cold head during return shipment.
- Place the compressor package on the pallet on top of sufficient vibration dampening material to prevent the wheels from touching the pallet.

- Strap the compressor package to the pallet; making certain that there is sufficient insulating material between the compressor and the straps so the straps will not scrape any paint off the compressor package.
  - Using protective wrap, secure the original helium flex lines (included with compressor package) and place in container.
- 4) Be sure to include shipping labels on the box showing which side is up and making clear that the shipment is fragile.
  - 5) Cryomech highly recommends using “tip and tell” indicators. These indicators are helpful in determining whether your package was handled properly or not. Replace used “tip and tell” indicators with new ones (total of three).
  - 6) When the shipment is ready, please contact Cryomech for further instructions on shipping.

## 6 Section 6: Installation

### 6.1 Cold head installation

The entire section on the cold head installation should be reviewed before installing the cold head.

#### **IMPORTANT**

*Failure to follow these installation guidelines could result in voiding the warranty.*



#### **CAUTION**

Because the tubes in the cold head must have very thin walls for cryogenic performance, extreme care must be taken when handling the cold head. *The warranty will not cover dented or bent tubes.*



#### **CAUTION**

*Operating the cold head in a magnetic field of greater than 500 gauss will void the warranty.*

#### 6.1.1 Unpack the cold head from shipping box

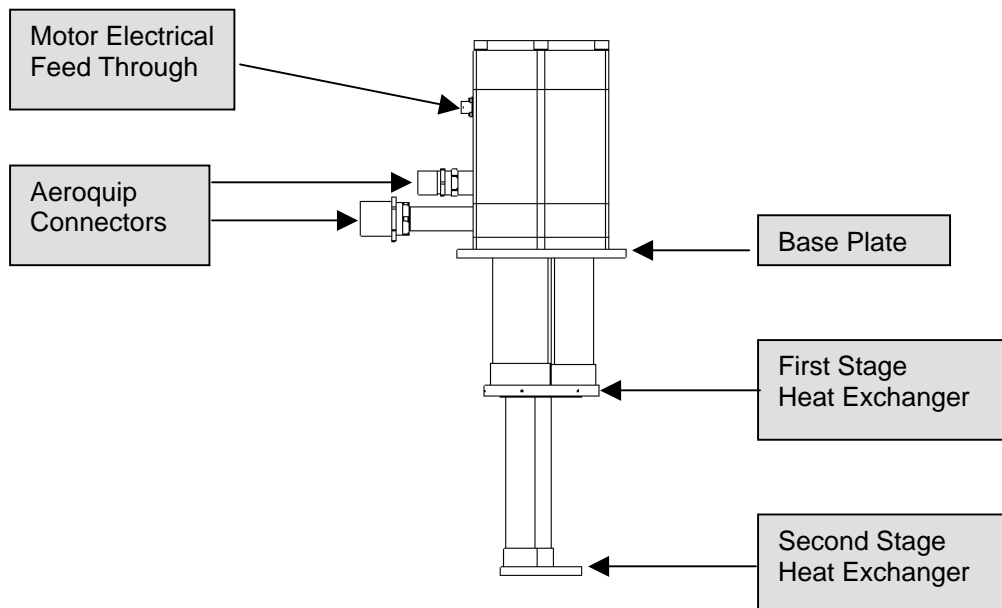

**Figure 4: Schematic of the PT405 cold head**

- 3) Locate the cold-head shipping box marked with *PT405 cold head*.

- 4) Adjust the box containing the PT405 cold head so the screw heads are on the side facing you. Remove the screws and open the box. Retain the box and the screws for future use.
- 5) Carefully remove packing material to expose cold head. Retain the packing material for future use.
- 6) Carefully remove the cold head and place horizontally on a clean, secure work surface.
- 7) Remove all protective material from the cold head.

### 6.1.2 Initial preparation of the cold head

- 8) Clean the mating surface of the base plate with isopropyl alcohol.
- 9) Apply a small amount of vacuum grease to the mating flange O-ring (not supplied) and insert in the O-ring groove. Cryomech recommends the use of a 2-256 Buna N O-ring for proper interface between flanges.
- 10) Join the mating flange of the vacuum chamber onto the cold head. Secure the flange to the base plate with screws by tightening evenly around the mating surface. Cryomech recommends eight 6mm screws for securing to mating flange.



#### **CAUTION**

Because the tubes in the cold head must have very thin walls for cryogenic performance, extreme care must be taken when handling the cold head. Take special care to not bend the tube assemblies. *Bent tubes will violate the system's warranty.*

- 4) Prepare the desired cold mating surface(s) and, applying a small amount of Apiezon® N grease or pure Indium foil on all cold mating surfaces, secure to the heat exchanger(s) using brass screws.



#### **CAUTION**

Do not apply heat directly to the cold head (e.g. soldering anything to the cold head heat exchanger(s), see Figure 4). Doing so will damage the cold head and void the warranty. *The warranty will not cover heating of the cold head over 325K (125°F, 52°C).*

### 6.1.3 Optimal installation of temperature sensors (optional)

If the application requires the use of temperature sensors to monitor performance, there are three major areas that are critical to proper monitoring:

- 11) Proper mounting of the sensor(s) on the heat exchanger(s)
- 12) Proper joining of sensor lead wires and connecting wires
- 13) Thermal anchoring of the lead wires to the heat exchanger(s)

Many reports of poor performance are traced back to problems in one of the three above areas.

Please refer to the Technical Manual if you need more specific details on installation of the sensors.

### 6.1.4 Installation of heaters (optional)

If the application requires the use of heaters to optimize performance, there are three major concerns that are critical to optimum performance:

- 1) Proper mounting of the heater(s) on the heat exchanger(s)
- 2) Proper joining of heater lead wires and connecting wires
- 3) Thermal anchoring of the lead wires to the heat exchanger(s)

Many reports of poor performance are traced back to one of the three above areas.

Please refer to the Technical Manual if you need more specific details on installation of heaters.

### 6.1.5 Mounting the radiation shield (optional)

- 1) Clean the radiation shield with isopropyl alcohol.
- 2) Apply a small amount of Apiezon® N grease or pure Indium foil on the shield mating surface. Attach the radiation shield with six 5mm brass screws. Tighten it evenly to the first stage heat exchanger.

## 6.2 Compressor installation

The entire section on compressor installation should be reviewed before installing the compressor package.

### **IMPORTANT**

*Failure to follow these installation guidelines could result in voiding the warranty.*

### 6.2.1 Step 1 -- Prepare the compressor package location

- Confirm that the physical space containing the compressor package has an ambient temperature in the range 45 to 100°F (7 to 38°C).
- Place the compressor package in a level position. For the compressor package to operate under optimal conditions, it must be oriented within 5° of being level.



### **WARNING**

The compressor package must be positioned to provide easy access to the front-panel mounted circuit breaker.

- Position the compressor package so there is sufficient space around it for changing the adsorber. If the compressor package cannot be moved easily to an open area, leave approximately 2 additional feet (0.6m) clearance above and to the left and right of it. Allow for 2 feet (0.6m) of clearance around all four sides and 3 feet (1m) of clearance above air-cooled models for proper air flow.



## 6.2.2 Step 2 – Connect the water lines to the compressor (water-cooled models only)



### **CAUTION**

Cooling water must meet the requirements in section 4.2. If water that does not meet the cooling water specifications in section 4.2 is introduced into the system, even for cleaning purposes, it will void the warranty.



### **CAUTION**

Do not apply heat to the cooling water inlet and outlet connectors located on the front panel of the compressor (see Figure 3).

*NOTE: This step applies only to water cooled models only. If your compressor package is air cooled, continue on to Step 3, below.*

- 1) Make sure that the cooling water supply is turned OFF.
- 2) Apply Teflon tape or pipe sealant to the threads on the male fittings (1/4 MPT) that you provide to connect to both the cooling water inlet connection and the cooling water outlet connection.
- 3) Attach the supply line from the water source to the cooling water inlet fitting. Turning the fitting clockwise, first hand-tighten the connection. Use a 3/4" wrench to keep the cooling water inlet fitting from turning, and use another wrench to tighten the water source supply line fitting until snug.
- 4) Attach the return line from the water source to the cooling water outlet fitting. Turning the fitting clockwise, first hand-tighten the connection. Use a 3/4" wrench to keep the cooling water outlet fitting from turning, and use another wrench to tighten the water source return line fitting until snug.
- 5) Turn the cooling water supply ON and check for leaks.
- 6) Make certain the cooling water flow rate and inlet temperature meets the requirements in section 4.2.

## 6.2.3 Step 3 – Connect the helium flex lines to the cold head and compressor package



### **CAUTION**

Follow the procedure carefully when connecting and disconnecting the helium flex lines. Failure to follow the procedure can cause accidental coupling disassembly, destruction of the sealing O-ring, and helium loss.

- 1) Remove all dust caps and plugs from the helium flex lines, compressor package and cold head and place in tool kit. Save dust caps and plugs for future use.

- 2) Ensure that the flat gaskets located in the male halves of the couplings are attached to both the cold head and the compressor package and be certain that they are seated properly.
- 3) With a dry, clean lint-free cloth remove any visible particles from the ends of the Aeroquip® couplings.
- 4) NOTE: The high-pressure and low-pressure helium flex lines are not interchangeable. The low-pressure line is equipped with  $\frac{3}{4}$ " Aeroquips® at each end. The high-pressure line is equipped with a  $\frac{1}{2}$ " Aeroquip® and a  $\frac{3}{4}$ " Aeroquip® on each end.
- 5) With the wrenches supplied in the tool kit, connect the low-pressure helium flex line to the low-pressure port on the cold head. The low-pressure port is marked "Low". Tighten the connector until a positive stop is felt. *When attaching the Aeroquip® to the mating connector, make sure the threads are in alignment before you tighten the connector.*



**Figure 5: Connecting the Aeroquip® on the low pressure flex line to the low pressure connection on the cold head.**

- 6) With the wrenches supplied in the tool kit, connect the other end of the low-pressure helium flex line to the low-pressure port on the compressor package front panel. The low-pressure port is marked "LOW". Tighten the connector until a positive stop is felt.

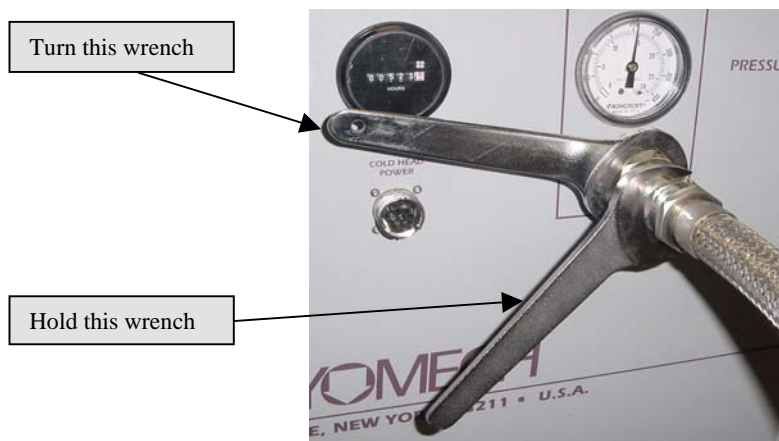

**Figure 6: Connecting Aeroquips® to or disconnecting Aeroquips® from the compressor package**

- 7) With the wrenches supplied in the tool kit, connect the high-pressure helium flex line to the high-pressure port on the cold head. The high-pressure port is the smaller of the two ports on the cold head and is marked "HIGH." Tighten the connector until a positive stop is felt.
9. With the wrenches supplied in the tool kit, connect the high-pressure helium flex line to the high-pressure port on the compressor package front panel. The high-pressure port is marked "HIGH". Tighten the connector until a positive stop is felt.

**WARNING**

Never remove the Aeroquip® couplings from the helium flex lines without first relieving the helium charge in the line to acceptable levels. The pressure in the hose can blow off the coupling with sufficient force to cause injury.

#### 6.2.4 Step 4 – Connect the cold head motor cord

- 1) Note that the female plugs attached to each end of the cold head motor cord are unique for both the compressor and the cold head.
- 2) Assure that the cold head motor cord is sufficiently long to reach the cold head. *If the cord length is not sufficient to reach the cold head, adjust the location of the compressor package or the cold head.*
- 3) To connect the cold head motor cord to the cold head, make sure that the alignment pins on the cold head receptacle correspond to the alignment grooves on the plug. Turn the plug sleeve clockwise while pushing the plug into the receptacle. The plug is designed to "click and lock" when assembly is completed.
- 4) To connect the cold head motor cord to the compressor, align the pins on the plug with the grooves on the compressor's connector. Push the plug onto the connector and turn the locking ring clockwise until snug.

#### 6.2.5 Step 5 – Connect the compressor package to the main power

**IMPORTANT**

A voltage deviation of more than 10% above or below the voltage rating can cause compressor motor overheating and possible failure. *Indications of operation outside that voltage range will void the compressor warranty.*

- 1) The system **MUST** be connected to a dedicated circuit breaker. The breaker must be mounted near the compressor package, within easy reach of the operator, and must be marked as the disconnecting device for the system. Specifications for circuit breakers vary according to the system's operating voltage. See the electrical specification tables in Section 4.2 for more information.
- 2) The compressor package comes with a main power cord attached. Assure that the length of the cord is sufficient to safely connect to the power source. If the cord is not sufficiently long, adjust the location of the compressor package.

**IMPORTANT**

*Be sure to follow all local electrical codes and guidelines.*

Make sure that the dedicated circuit breaker is turned OFF.

10. The ground (or earth) wire in the power cord is either green (60 Hz systems) or green/yellow stripe (50 Hz systems). Connect the ground wire in the power cord to the ground (or earth) connector in the breaker panel, making sure to tighten the wire into the connector securely. It is important not to disable this wire.
11. Connect the remaining hot wires in the power cord to the corresponding lugs on the dedicated breaker in the breaker panel, making sure to tighten the connector securely. The order of the wires is not important at this time - correct order will be determined in Step 7.



### **WARNING**

One lead of the compressor package is grounded. Never bypass this ground or attach the compressor package to an ungrounded circuit. A dangerous electrical hazard will develop.

## **6.2.6 Step 6 – Remove excess helium from the compressor package prior to running the system for the first time**

### **IMPORTANT**

The system is shipped from the factory with excess helium in order to allow for some loss when assembling system components. *Complete this step ONLY if the actual system pressure exceeds the pressure indicated in Item 1, below.*

- 3) Observe both the low and high pressure gauges located on the front panel and determine which gauge has the lower reading. If the system helium pressure shown on the lowest reading gauge EXCEEDS 225 PSIG (13.4 bar) for 60 Hz models or 195 PSIG (14.8 bar) for 50 Hz models, follow the procedures in this step. Otherwise, skip this step and go to Step 7, below.
- 4) Assuming pressures exceed those indicated in Step 1, above, first make sure that the service valve (located on the front panel) is CLOSED (turned fully clockwise).
- 5) Attach the ¼" service Aeroquip® coupling to the service access.
- 6) Turning the service valve counter-clockwise, open the valve SLOWLY. Do not vent more than 5 PSIG (.34 bar) of gas per minute.
- 7) Observe the gauge with the lower reading. Once the gauge reaches the system helium pressure indicated in Step 1, close the service valve by turning clockwise and remove the service Aeroquip® from the service access.

## **6.2.7 Step 7 – Run the system for the first time**

- 1) Recheck all helium flex line, electrical and (*water cooled models only*) water supply connections to make sure they are correct and tight.
- 2) Energize the dedicated circuit breaker.
- 3) (*Water-cooled models only*) Turn on the water flow to the specified level.
- 4) Energize the circuit breaker located on the front panel of the compressor package by moving the breaker from the OFF to the ON position.

- 5) By pressing the power switch on the front panel of the compressor package, turn on the compressor package.



**CAUTION**

*Running the compressor package in reverse for any significant length of time will void the warranty. If the power cord is not wired properly the compressor will run in reverse and there will be no pressure differential on the pressure gauges. Turn the system off immediately. Follow the instructions in section 6.2.7 to rewire the power plug correctly.*

- 6) *Immediately* check the low and high pressure gauges for a pressure differential of at least 200 PSIG (13.76 bar). If the system is functioning correctly, there will be an immediate increase in the high pressure gauge and an immediate decrease in the low pressure gauge and you have successfully operated your system for the first time. If there is **NOT** an immediate pressure differential, it means the compressor package is out of phase and the system is operating in reverse.



**CAUTION**

You must turn off the compressor package immediately in order to prevent damage to the compressor package. Then perform Item 7, below.

- 7) Perform the following steps to correct a reversed compressor package:
  - a. Turn off the main power switch.
  - b. Switch off the breaker on the front panel of the compressor package.
  - c. Turn off the dedicated circuit breaker to disconnect the system from power at the source (to prevent electrical shock).
  - d. Examine the power cord and wire colors at the panel circuit breaker.

60 Hz configuration		50 Hz configuration	
<b>Hot –</b> .....	Black	<b>Hot –</b> .....	Black (One - 1)
<b>Hot –</b> .....	Red	<b>Hot –</b> .....	Black (Two - 2)
<b>Hot –</b> .....	White	<b>Hot –</b> .....	Black (Three - 3)
<b>Ground –</b> .....	Green	<b>Ground (or Earth) –</b> ..	Green w/ Yellow Stripe

**Figure 7: Color codes for 60 Hz and 50 Hz models**

- e. If your system contains a 60 Hz power cord, switch the black and red wires. If your system contains a 50 Hz power cord, swap any two black wires.
- f. Energize both breakers and press the main power switch. The compressor package should now operate properly and create the pressure differential as specified in Step 6, above.

=====  
=====

**Environment**

The compressor package is designed to operate in an ambient temperature range from 45°F to 100°F (15-37°C). If the temperature is below 45°F, the increased viscosity of the oil could prevent start-up and/or cause poor lubrication. Operation above 100°F will cause overheating and subsequent problems. *If a unit must be subjected to either extreme, Cryomech must be consulted.*

To avoid electrical shock danger, make sure there is no direct contact with water.

## 7 Section 7: Operation

### 7.1 Starting the system

#### 7.1.1 Checks before operating

- 1) Check the system pressure - the gauges should read  $220 \pm 5$  PSIG ( $15.2 \pm .34$  bar) for 60Hz models or  $190 \pm 5$  PSIG ( $13.1 \pm .34$  bar) for 50Hz models.
  - o If the pressure is too high, vent some of the helium following the instructions in section 8.2.
  - o If the pressure is too low, add helium following the instructions in section 8.2.
- 2) Make sure the cold head motor cord is connected to both the compressor and the cold head.
- 3) Make sure all Aeroquip® couplings are securely fastened and the helium flex lines are oriented correctly.
- 4) Make sure the input power meets the specifications on the identification label.



#### **CAUTION**

A voltage deviation of more than 10% above or below the voltage rating can cause compressor motor overheating and possible failure. *Indications of voltage operation outside that range will void the compressor warranty.*

- 5) (*Water cooled models only*) Make sure the flow rate and temperature range of the cooling water meet the requirements shown in Figure 1 in section 4.2.
- 6) Check that the circuit breaker is on.



#### **CAUTION**

*Operating the cold head in a magnetic field of greater than 500 gauss will void the warranty.*

#### 7.1.2 Startup procedure



#### **CAUTION**

*Running the compressor package in reverse for any significant amount of time will void the warranty.* If the power cord is not wired properly the compressor will run in reverse and there will be no pressure differential on the pressure gauges. Turn the system off immediately. Follow the instructions in section 6.2.7 to rewire the power cord correctly.

- Turn on the system by pressing the power switch on the front panel of the compressor package.

- Check the pressure gauges for an immediate pressure differential of at least 200 PSIG (13.76 bar). There must be an immediate increase in the high pressure and an immediate decrease in the low pressure.
- If there is no pressure differential or it is less than 200 PSIG (13.76 bar), the compressor package is running in reverse.
  - o Turn off the power switch immediately.
  - o Follow the instructions in section 6.2.7 number 7 to correct the wiring of the power cord.
  - o Restart the system.

## 7.2 Normal operation behavior

### Cool down time

An unloaded PT405 cryorefrigerator with no additional mass on the heat exchangers will cool down to 2.8 in less than 60 minutes. When additional mass is attached to either stage, the cool down time will increase.

### Normal pressures and pressure differentials

When a 60 Hz system is first started, normal pressures are in the range of  $220 \pm 5$  PSIG ( $15.2 \pm .34$  bar).

When a 50 Hz system is first started, normal pressures are in the range of  $190 \pm 5$  PSIG ( $13.1 \pm .34$  bar).

The typical pressure differential is approximately 250 PSIG (17.2 bar) with 5 - 10 PSIG (.34 - .7 bar) bounce on the needles.

As the PT405 cold head cools down it draws more helium and the pressure differential decreases.

### Normal temperatures

For two-stage 4K models, a 1<sup>st</sup> stage temperature of approximately 30K and a 2<sup>nd</sup> stage temperature of less than 3K should be attained.

These temperatures will vary depending on the quality of the vacuum, the quality of the super-insulation, and the heat load brought in by the instrumentation leads. Please see the specifications sheet in the appendix for more information.

### Normal sounds

When operating properly, the cryorefrigerator will emit a rhythmic squeak or chirp approximately 80 times per minute. This noise is an indication of the proper flow of helium gas within the system.

## 7.3 Recommended routine procedures

### INFORMATION

It is helpful to monitor the PT405 cryorefrigerator daily in order to detect changes in performance early. These changes can signify degradation in performance that could result from the beginning of a problem that requires attention.



Cryomech recommends keeping regular logs of key measurements at intervals that make sense for the way you use your system.

### **7.3.1 High and low pressure**

Changes in the high and low pressure readings on the compressor package's gauges are used for diagnosing several different types of problem. It is important to know whether changes are sudden or gradual and to know how the high and low pressures are changing relative to each other.

The high and low pressures should be monitored daily.

Cryomech recommends that you maintain a regular record, at intervals that make sense for the way you use your system, of the pressure of the high pressure gauge and of the low pressure gauge on the front panel of the compressor package.

### **7.3.2 Cold head temperature**

Temperature changes are the other key diagnostic.

If a temperature sensor is attached to either of the heat exchangers in the cold head, Cryomech strongly recommends that you monitor the temperature(s) daily.

Cryomech also recommends that you keep a regular record of the temperature at intervals that make sense for the way you use your system.

### **7.3.3 Cooling water input and output (water-cooled models only)**

If possible, Cryomech recommends keeping a regular record of the input and output cooling water temperatures and of the cooling water flow rate.

## **7.4 Shutdown procedure**

Press the power switch on the front panel of the compressor package (see Figure 3). This will shut down the entire system.

## **7.5 Disassembling the system for transport or storage**

Use the following steps to prepare a Cryomech cryorefrigerator for eventual transport or storage.

- 1) Make sure that on/off switch on the front panel is in the OFF position.
- 2) Disconnect the power to the system by switching the front panel breaker to the OFF position.
- 3) Disconnect the main power to the system by switching the dedicated breaker to the OFF position.
- 4) *(Water-cooled models only)* Turn off the water supply at the source.
- 5) Disconnect the power cord from the external breaker panel. Coil up the power cord in preparation for transport or storage.
- 6) Disconnect the cold head motor cord from the cold head and from the compressor. Coil the cold head motor cord in preparation for transport or storage.
- 7) *(Water-cooled models only)* Using two wrenches, disconnect the supply and return water lines from the inlet and outlet fittings by turning the fittings counter-clockwise

until they are released from the FPT fittings. Store the connectors for transport or storage.

- 8) (*Water-cooled models only*) Drain the water from the compressor package. Blow remaining water out with compressed air.

### **IMPORTANT**

Do not continue with the remaining steps until the cold head temperature has risen above 150K. If the cold head is disconnected from the system while below 150K, helium will expand within the cold head as it warms, escape through the pressure relief valve and require the user to recharge the system with helium before it would again operate properly.

- 9) Verify that the cold head temperature is 150K or above. Then, using the wrenches supplied in the tool kit, disconnect the high pressure Aeroquip® on the compressor package by turning the Aeroquip® counter-clockwise with one wrench while holding the other wrench to prevent the flex line from twisting.

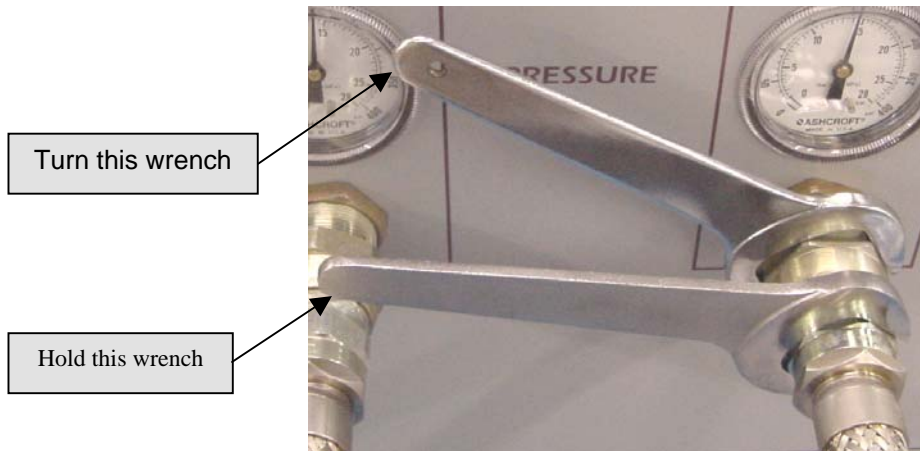

**Figure 8: Disconnecting Aeroquips® from the compressor package**

- 10) Using the same method as in Step 8, disconnect the Aeroquip® on the high pressure fitting on the cold head.



**Figure 9: Disconnecting Aeroquips® from the cold head**

- 11) Using the same method as in Step 8, disconnect the Aeroquip® on the low pressure fitting on the compressor package.
- 12) Using the same method as in Step 8, disconnect the Aeroquip® on the low pressure fitting on the cold head.
- 13) Install the dust plugs (that originally came with the system and are stored in the tool kit) on the helium flex line fittings and install the dust caps on both the compressor package and the cold head.
- 14) If necessary, disconnect the cold head from its mounting surface, taking care not to damage any components. Once disconnected, place the cold head in the original packaging container.
- 15) Recoil the helium flex lines and prepare for transport or storage.
- 16) Assure that all components are stored in appropriate containers and location.

## 7.6 Troubleshooting

### 7.6.1 System will not start

SYMPTOM	System will not start
POSSIBLE CAUSE	<ol style="list-style-type: none"> <li>1) No power supplied to the compressor package.</li> <li>2) Circuit breaker off.</li> <li>3) Pressure switch tripped.</li> <li>4) Temperature switch tripped.</li> </ol>
REMEDY	<p>Check the power supply to the system and verify that it meets the requirements outlined in section 4.2.</p> <ol style="list-style-type: none"> <li>5) Make certain the circuit breaker, located on the front panel of the compressor package, is on.</li> <li>6) Reset the pressure switch located on the bottom of the front panel of the compressor package as shown in Figure 3.</li> <li>7) Reset the temperature switch located on the bottom of the front panel of the compressor package as shown in Figure 3.</li> </ol>

### 7.6.2 System starts, no pressure fluctuation

SYMPTOM	System starts, no bounce in the pressure gauges, no refrigeration.
POSSIBLE CAUSE	<ol style="list-style-type: none"> <li>1) Cold head motor cord not connected to the cold head and/or to the compressor package.</li> <li>2) Aeroquip® connector(s) not completely tightened.</li> <li>3) High and low pressure helium flex lines reversed.</li> </ol>
REMEDY	<ol style="list-style-type: none"> <li>1) Turn off the power switch and connect the cold head motor cord to the cold head and/or to the compressor package.</li> <li>2) Tighten all Aeroquip® connectors.</li> <li>3) Verify that one of the helium flex lines connects the high pressure port on the compressor package to the high pressure port on the cold head and that the other helium flex line connects the low pressure ports.</li> </ol>

**7.6.3 System has shut itself down. Power switch light off**

<b>SYMPTOM</b>	System has shut itself down. Power switch light off.
<b>POSSIBLE CAUSE</b>	<ol style="list-style-type: none"> <li>1) Circuit breaker tripped.</li> <li>2) Interruption of the power supply to the compressor package.</li> <li>3) Pressure switch tripped.</li> <li>4) Temperature switch tripped.</li> </ol>
<b>REMEDY</b>	<ol style="list-style-type: none"> <li>1) Reset the circuit breaker on the front panel of the compressor package.</li> <li>2) Check the power supply to the system and verify that it meets the requirements outlined in section 4.2.</li> <li>3) Check the static helium charge in the system. With the complete system at room temperature, the static helium charge must meet the specification outlined in section 4.2. If the helium charge is within the specification, reset the pressure switch located on the bottom of the front panel of the compressor package as shown in Figure 3.</li> <li>4) Make certain the cooling water flow rate and inlet temperature meets the specification outlined in section 4.2. Reset the temperature switch located on the bottom of the front panel of the compressor package as shown in Figure 3. The switch will not reset until its sensor has cooled approximately 15°F (8.3°C).</li> </ol>

**7.7 Contact Cryomech with Questions**

It is hoped that the Operations Section of this manual has helped you to obtain satisfactory results in the use of your Cryomech PT405 cryorefrigerator. While the information offered should facilitate set up and operation, you may have a special situation that requires further considerations. If after reading the Operations Section, you still have questions, contact Cryomech for further information.

**7.7.1 Contact Information**

Cryomech, Inc.  
113 Falso Drive  
Syracuse, NY 13211

Phone: (315) 455-2555  
Fax: (315) 455-2544

Email: [specs@cryomech.com](mailto:specs@cryomech.com)  
Website: [www.cryomech.com](http://www.cryomech.com)

## 8 Section 8: Routine Maintenance

### 8.1 Introduction

This section contains basic, essential maintenance information. For more detailed information, consult the technical manual, which can be obtained by contacting Cryomech.

### 8.2 Cryorefrigerator system

#### 8.2.1 Adjust helium pressure - vent excess helium

This procedure should only be used to vent small quantities of helium from an overcharged system.

- 4) Make sure the service valve is closed
- 5) Attach the small service Aeroquip® coupling to the service access port.
- 6) Open the service valve slowly. Do not vent more than 5 PSIG (.34 bar) of helium per minute.
- 7) After venting the helium, close the service valve and remove the service Aeroquip® from the service access port.



#### **CAUTION**

Venting more than 5 PSIG (.34 bar) of helium per minute will lead to improper oil migration within the system. If this condition occurs, factory service will be required.

#### 8.2.2 Adjust helium pressure - recharge helium



#### **CAUTION**

When adding helium, the helium must be 99.999% pure. Contamination by other gases will result in the freezing of the contaminant gases in the cold head because their freezing temperature is much higher than that of helium. Contaminants in the helium charge will severely degrade the cold head's function and it will require factory servicing.

*Contamination of the helium by other gases is a common cause of premature failure and, unless resulting from a system failure, is not covered by the warranty.*

This procedure should be performed with the compressor package shut down. Adding helium is possible whether or not the cold head is attached to the compressor package. Both the service access and service valve are connected to the low-pressure manifold of the compressor.

- 1) Turn the system off.

- 2) Allow the entire system, both the compressor package and the cold head, to come to room temperature.
- 3) Use only high purity helium with a minimum purity of 99.999%.
- 4) Check that the helium source and regulator are capable of pressurizing to the desired pressure.
- 5) Make sure the service valve is closed.
- 6) Attach the service Aeroquip® coupling to the service access port.
- 7) Attach a charging line from the service Aeroquip® to a typical vacuum/charging manifold as shown in Figure 10 below.



**Figure 10: Helium recharging assembly**

- 8) Evacuate to 50 microns.
- 9) Isolate the vacuum pump and add 50 PSIG (3.4 bar) of helium.
- 10) Vent the helium and repeat steps 8 to 10.
- 11) Final evacuation should be to 25 microns.
- 12) Pressurize the line to the service access with the desired amount of helium pressure.
- 13) Slowly open the service valve to add helium to the system. Final helium charge in the system should be  $220 \pm 5$  PSIG ( $15.2 \pm .34$  bar) for 60 Hz systems or  $190 \pm 5$  PSIG ( $13.1 \pm .34$  bar) for 50 Hz systems.



**CAUTION**

No more than 5 PSIG (.34 bar) of gas should be added per minute to prevent internal oil contamination to the system. If such contamination occurs, factory service will be required.

12. After adding the helium, close the service valve and remove the service Aeroquip® from the service access.

## 8.3 Compressor package

### 8.3.1 Replace the adsorber



#### **CAUTION**

At no time should the Aeroquip® couplings be removed from the adsorber when replacing the adsorber. Replacement can be completed without relieving system pressure since the adsorber is equipped with Aeroquip® couplings for sealed removal.

The adsorber should be replaced at 20,000-hour intervals as part of routine maintenance.

- 1) Remove the chassis cover from the compressor package.
  - a. Remove the 8 quarter-turn screws that hold the cover on and retain them.
  - b. Lift the cover straight up and off.

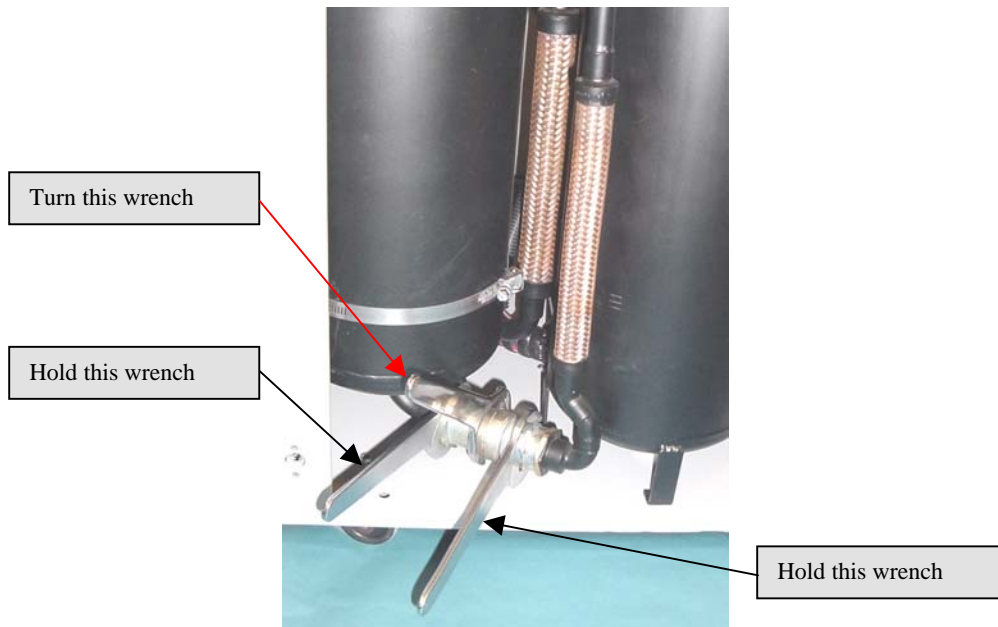

**Figure 11: Disconnecting the adsorber.**

- 2) Disconnect the high-pressure helium flex line from the compressor.
- 3) Using three wrenches, disconnect the Aeroquip® coupling between the adsorber and the oil separator as shown in Figure 11.
- 4) Remove the nut holding the high-pressure Aeroquip® coupling to the front panel.
- 5) Loosen and disconnect the hose clamp that attaches the adsorber to the front panel.
- 6) Remove the adsorber from the compressor package.
- 7) Check the Aeroquip® couplings for oil residue. If oil is present, contact Cryomech for further assistance.
- 8) To install the new adsorber, reverse steps 1) through 6).



### 8.3.2 Replace the air filter (air cooled models only)

The air filter should be replaced at 2,000-hour intervals as part of routine maintenance.

- 8) Lift the air filter access panel, located on the front of the compressor package, to gain access to the air filter.
- 9) Pull the air filter out.
- 10) Slide in a new air filter making sure the air flow arrow on the filter is pointing up.
- 11) Close the access panel.

## 8.4 Servicing the cold head



### **CAUTION**

The cold head contains no user-serviceable parts. *Attempting to disassemble the cold head will void the warranty.*

CONTACT CRYOMECH IF THE COLD HEAD NEEDS TO BE RETURNED FOR SERVICING.

## 8.5 Other maintenance items

### 8.5.1 Cleaning

#### **Compressor package and cold head**

The compressor package and cold head require no cleaning other than wiping the outside of each if it becomes dusty or dirty.

Never wet either part of the system. *Water getting into the system will void the warranty.*

#### **Aeroquip® couplings**



### **CAUTION**

Never remove an Aeroquip® coupling from the helium flex line.

If operated in a clean environment, the only parts of the cryorefrigerator system that are likely to require cleaning are the Aeroquip® couplings. The mating surfaces of the Aeroquip® couplings can get particles on them when the helium flex lines are detached from the compressor package and/or the cold head.

If an Aeroquip® coupling needs cleaning:

- Wipe the mating surfaces of the coupling with a dry, lint-free cloth.
- After wiping, blow off the coupling with clean, dry compressed air.
- Solvents should never be used.
- If any grease or oil gets on the Aeroquip® coupling, contact Cryomech.

## 8.5.2 Replaceable fuses

See the Fuse Specifications table in section 4.2 for the ratings and characteristics of all replaceable fuses.

Qualified service personnel only should replace the fuses.

## 8.5.3 Manufacturer only parts

The following parts are available only from Cryomech:

### Helium flex lines

The helium flex lines must be handled with care. If they become damaged and need to be replaced, new ones must be obtained from Cryomech and installed using the directions in the installation section of this manual.

### Adsorber

The adsorber needs to be replaced after every 20,000 hours of use. See section 8.2.4 for instructions on replacing the adsorber.

### Cold head

The cold head contains no user-serviceable parts and must be serviced by Cryomech authorized technicians. *Attempting to disassemble the cold head will void the warranty.* See section 8.3.

### Main power cord

If the power cord becomes damaged, a replacement should be obtained from Cryomech. See the power cord replacement instructions below.

### Cold head motor cord

If the cold head motor cord becomes damaged, a replacement must be obtained from Cryomech.

## 8.5.4 Cord replacement details:

### Main power cord

- 9) Disconnect the compressor package from its electrical power source.
- 10) Remove the eight 1/4-turn fasteners that secure the compressor package cover and remove the cover.
- 11) Prepare a suitable replacement cable - 10 AWG / 4 Conductor rated for 600V. Remove the cord jacket 12" from the end, and strip the insulation from the conductors 1/2" (12.5mm) from the end.
- 12) Remove the two screws holding the circuit breaker to the front panel of the compressor package.
- 13) Pull the circuit breaker away from the inside surface of the front panel.
- 14) Disconnect the existing cord from circuit breaker and ground lug, and remove from the strain relief
- 15) Install the new cord through the strain relief, and connect to the circuit breaker and the ground lug. Tighten the screws to 31 lb-in (3.5 N-m).

- 16) Reattach the circuit breaker to the front panel of the compressor package.
- 17) Connect the other end of the cable to the power source in accordance with local electrical codes. Make sure that the main power cord ground lead is connected properly. It is important not to disable this lead.
- 18) Perform phase check/operation check per section 6.2.7 Step 7.
- 19) Reinstall the cover that was removed in Step 2.

**WARNING**

One lead of the compressor system is grounded. Never bypass this ground or attach the compressor to an ungrounded circuit. A dangerous electrical hazard will develop.

## 8.6 Service

### 8.6.1 Cryomech contact information:

Cryomech, Inc.  
113 Falso Drive  
Syracuse, NY 13211

Phone: (315) 455-2555

Fax: (315) 455-2544

Email: [specs@cryomech.com](mailto:specs@cryomech.com)

Website: [www.cryomech.com](http://www.cryomech.com)

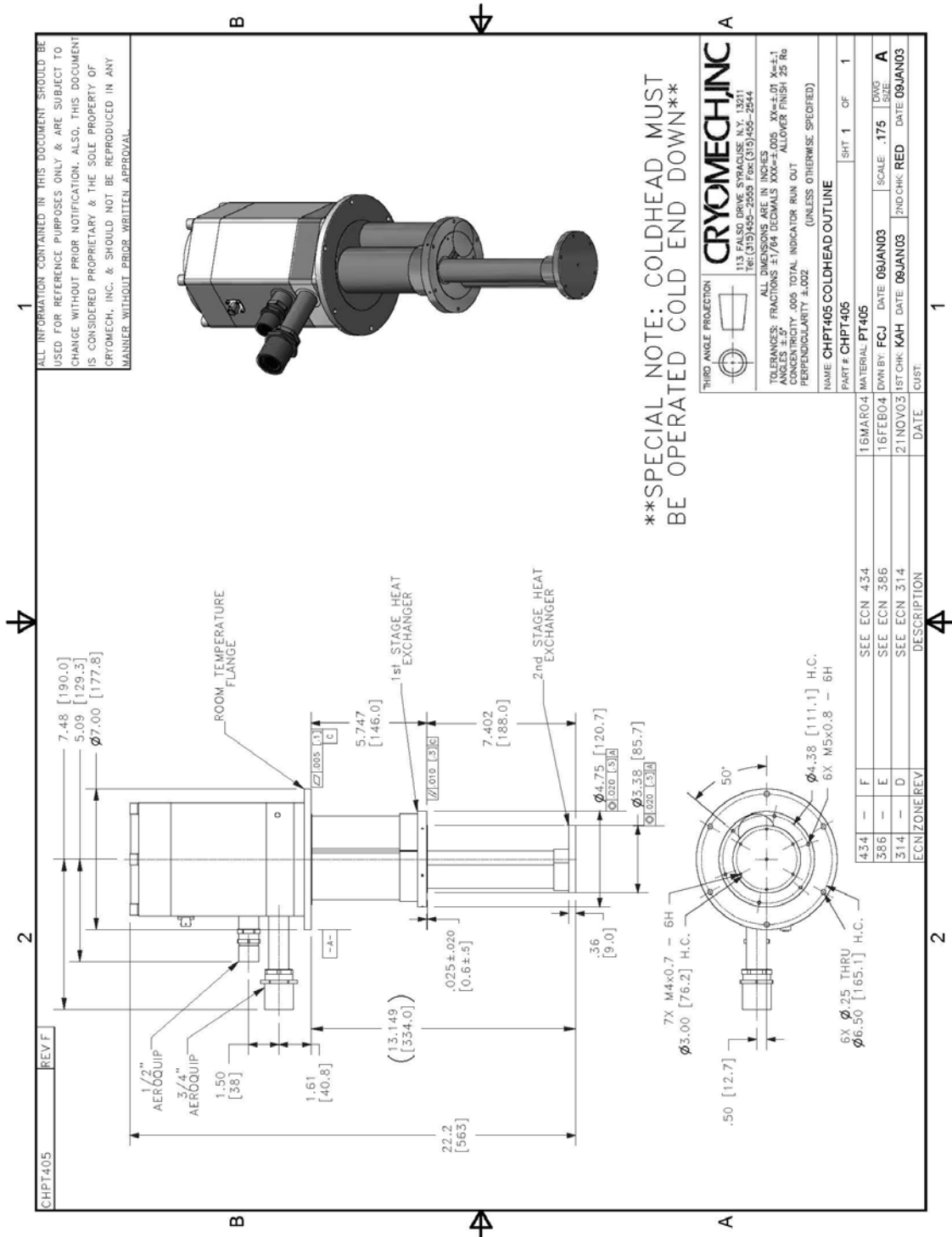

Figure 12: PT405 Cold Head Line Drawing

CP900 - PT  
 200/220VAC, 3PH, 50Hz  
 220/230VAC, 3PH, 60Hz  
 380/420VAC, 3PH, 50Hz  
 460VAC, 3PH, 60Hz

BK- BLACK GR/YL- GREEN YELLOW RD- RED  
 BL- BLUE CY- GRAY WH- WHITE  
 BR- BROWN OR- ORANGE YL- YELLOW

NOTE 1: TYPE CC TIME DELAY FUSE

60-120 DRAWN BY: AD  
 REV B APPROVED BY: NLO  
 ECN-758 06APR04

ECN REV	DESCRIPTION	DATE	ENGR
60-120	INITIAL RELEASE	25 MAR 04	1 1
REV A	SEE ECN 2463	06 APR 04	1 1
REV B	ADDED EMC FILTER	25 JUN 05	1 1

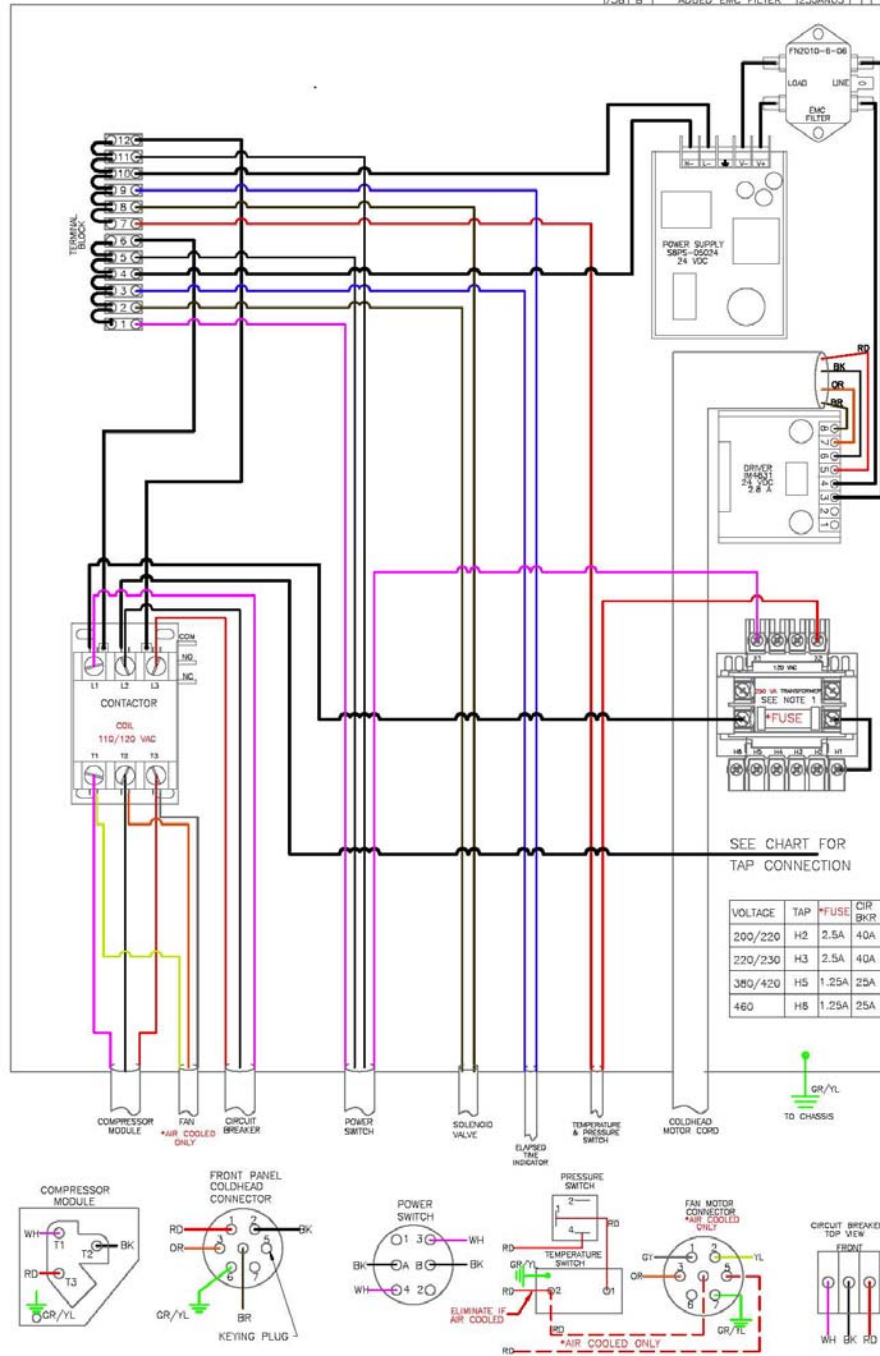

Figure 13: Electrical Schematic for the PT405 Cryorefrigerator